

# Urban Cleaning Equipment

GENERAL CATALOGUE - CATALOGO GENERALE

EN

IT



**PTC**  
master the water force

# INDEX

## SOMMARIO

<b>SEWER CLEANING</b>	<b>6</b>
<b>CONFIGURATIONS · CONFIGURAZIONI</b> .....	7
CJ-1E .....	8
CJ-2B .....	10
WHALE .....	12
WHALE-E electric/ <i>elettrico</i> .....	14
SALMON .....	16
SALMON-E electric/ <i>elettrico</i> .....	18
MOSES .....	20
HOT WATER KIT .....	22
CTR-C .....	24
JTR-C .....	26
<b>VACUUM &amp; COMBINED</b>	<b>28</b>
<b>CONFIGURATIONS · CONFIGURAZIONI</b> .....	29
VORTEX 400 · 800 · 1000 COMPACT .....	30
VORTEX 1000 SKID .....	32
VORTEX COMBI SEWER .....	34
VORTEX COMBI-E electric/ <i>elettrico</i> .....	36
VORTEX COMBI CLEANING .....	38
<b>HIGH PRESSURE CLEANING</b>	<b>40</b>
<b>CONFIGURATIONS · CONFIGURAZIONI</b> .....	41
TORNADO SKID .....	42
<b>POWERSTEAM-WEED CONTROL</b> .....	44
TORPEDO MINI-E .....	46
TORPEDO COMPACT .....	48
TORPEDO SKID .....	50
CTR-H .....	52
JTR-H .....	54
TORPEDO ELECTRIC .....	56

# LEGEND

## LEGENDA

	<b>Cold water pressure washers</b> <i>Idropultrici ad acqua fredda</i>		<b>Fuel tank (lt)</b> <i>Serbatoio combustibile (lt)</i>
	<b>Hot water pressure washers</b> <i>Idropultrici ad acqua calda</i>		<b>Fuel consumption (kg/h)</b> <i>Consumo combustibile (kg/h)</i>
	<b>Steam function</b> <i>Funzione vapore</i>		<b>RPM motor</b> <i>Giri motore</i>
	<b>Max pressure (bar/MPa)</b> <i>Pressione max (bar/MPa)</i>		<b>Diameter (inch - mm)</b> <i>Diametro (inch - mm)</i>
	<b>Water flow rate (l/h)</b> <i>Portata acqua (l/h)</i>		<b>Water tank (n° - litre)</b> <i>Serbatoio acqua (n° - litri)</i>
	<b>Absorbed power (kW)</b> <i>Potenza assorbita da rete (kW)</i>		<b>Without water tank</b> <i>Senza serbatoio acqua</i>
	<b>Electrical power supply</b> <i>Alimentazione da rete elettrica</i>		<b>Suction power</b> <i>Potenza di aspirazione</i>
	<b>Diesel power supply</b> <i>Alimentazione a Diesel</i>		<b>Sludgie tank capacity (lt)</b> <i>Capacità cisterna acque nere (lt)</i>
	<b>Gasoline power supply</b> <i>Alimentazione a benzina</i>		<b>Washing</b> <i>Lavaggio</i>
	<b>Electrical motor power (HP/kW)</b> <i>Potenza motore elettrico (HP/kW)</i>		<b>Portable configuration</b> <i>Configurazione portatile</i>
	<b>Engine power (HP/kW)</b> <i>Potenza motore a combustione (HP/kW)</i>		<b>Built-in configuration</b> <i>Configurazione Built-in</i>
	<b>Weight (kg)</b> <i>Peso (kg)</i>		<b>Trailer configuration</b> <i>Configurazione a rimorchio</i>
	<b>Dimensions (cm)</b> <i>Dimensioni (cm)</i>		<b>Skid configuration</b> <i>Configurazione Skid</i>
	<b>Outlet water temperature (°C)</b> <i>Temperatura uscita acqua (°C)</i>		



## COMPANY PROFILE

### INTRODUCTION

P.T.C. Srl is an Italian company founded in 1968 to offer itself as a player in the construction and sale of hydro-sandblasting systems which, using high-pressure water technology, were mainly used for naval and industrial maintenance.

Subsequently, the company diversified its business, supporting the URBAN CLEANING division, which offers a wide range of machines for all urban hygiene applications: high pressure washers, sewer cleaning and autonomous vacuums for the recovery of residues. available in combined version with high pressure washing unit.

HPP is our brand of piston pumps, which, thanks to the most modern technologies, allows us to offer a wide range of products and accessories from 16 to 410 KW, with pressures up to 2800 Bar. Today PTC is a company of international level with a wide range of products that cover all sectors of professional cleaning in the civil and industrial sectors.

### PRODUCTS

We offer a complete range of professional cleaning machines that allow you to work even where wet cleaning trucks have difficulty in accessing: historic centers, pedestrian areas, narrow streets, underpasses, etc. They are all built with our HPP pumps.

Machines with simple and intuitive control systems; Small dimensions and low consumption that allow quick and decisive interventions with low operating costs.

We also manufacture autonomous vacuum cleaners for the recovery and transport of non-hazardous liquids, purification residues, sludge, semi-solids, oils, etc.

Our high pressure washers are professional machines that combine the power of water under pressure with the sanitizing action of hot water and steam, allowing cleaning operations without the use of detergents and chemical additives. A solution that improves the quality and working conditions of operators, respecting the environment and reducing intervention costs.



## PROFILO AZIENDA

### INTRODUZIONE

P.T.C. Srl è un'azienda italiana nata nel 1968 per proporsi come player nella costruzione e vendita di impianti di idrosabbatura che, utilizzando la tecnologia dell'acqua ad alta pressione, venivano principalmente utilizzati per la manutenzione navale e industriale.

Successivamente l'azienda ha diversificato la propria attività, affiancando la divisione URBAN CLEANING, che offre un'ampia gamma di macchine per tutte le applicazioni di igiene urbana: idropultrici ad alta pressione, pulizia fognature e aspiratori autonomi per il recupero dei residui. disponibile in versione combinata con unità di lavaggio ad alta pressione.

HPP è il nostro marchio di pompe a pistoncini, che, grazie alle più moderne tecnologie, ci permette di offrire una vasta gamma di prodotti e accessori da 16 a 410 KW, con pressioni fino a 2800 Bar. Oggi PTC si propone come un'azienda di livello internazionale capace, con la sua ampia offerta, di coprire tutti i settori della pulizia professionale in ambito civile ed industriale.

### PRODOTTI

Offriamo una gamma completa di macchine per la pulizia professionale che consentono di lavorare anche dove i camion per la pulizia ad acqua hanno difficoltà di accesso: centri storici, aree pedonali, strade strette, sottopassi, ecc. Sono tutti costruiti con le nostre pompe HPP.

Macchine con sistemi di controllo semplici ed intuitivi; Piccole dimensioni e bassi consumi che consentono di effettuare interventi rapidi e decisi con bassi costi di esercizio.

Realizziamo inoltre aspiratori autonomi sottovuoto per il recupero e il trasporto di liquidi non pericolosi, residui di depurazione, fanghi, semisolidi, oli, eccetera.

Le nostre idropultrici ad alta pressione sono macchine professionali che uniscono la potenza dell'acqua in pressione all'azione igienizzante dell'acqua calda e del vapore, consentendo operazioni di pulizia senza l'utilizzo di detersivi e additivi chimici. Una soluzione che migliora la qualità e le condizioni di lavoro degli operatori, nel rispetto dell'ambiente e riducendo i costi di intervento.



# Sewer Cleaning

- Unblocking pipes
- Freeing drains
- Unblocking and cleaning wells
- Cleaning pipes
- Cleaning storm drains
- Surface cleaning
- *Disotturazione tubature*
- *Stasamento scarichi*
- *Pulizia e stasamento pozzetti*
- *Pulizia condotte*
- *Pulizia caditoie*
- *Pulizia superficiali*





## Units for flushing and sewer cleaning

### Unità da spurgo e stasamento condutture

Sewer Cleaning Unit, a complete range of professional cleaning machines that allow you to work even where the bleeding / canaljet vehicles have difficulty in accessing: historic centers, pedestrian areas, narrow streets, underpasses, etc. Machines with simple and intuitive control systems; Reduced dimensions and low consumption that allow to perform quick and decisive interventions with low operating costs.

*Unità Sewer Cleaning, una gamma completa di macchine per pulizie professionali che consentono di lavorare anche dove gli automezzi spurgo/canaljet hanno difficoltà di accesso: centri storici, aree pedonali, strade strette, sottopassi, etc. Macchine dai sistemi di controllo semplici ed intuitivi; Ingombri ridotti e bassi consumi che permettono di eseguire interventi rapidi e risolutivi con costi di utilizzo contenuti.*

#### CONFIGURATIONS · CONFIGURAZIONI

#### UNITS · UNITÀ



### PORTABLE

Portable units with electric or petrol engines for quick professional cleaning interventions. Simplicity of use and easy handling characterize this type of product.

*Unità portatili con motorizzazione elettrica o benzina per rapidi interventi di pulizia professionale. Semplicità di utilizzo e facile movimentazione caratterizzano questa tipologia di prodotto.*

CJ-1E

CJ-2B



### BUILT-IN

Built-In units, designed for vans and small trucks, are completely autonomous machines with petrol or diesel engines, **LIGHT** and **SUPER COMPACT**, they do not constrain the vehicles on which they are installed and adapt to the space needs of customers thanks to our tanks modular.

*Unità Built-In, progettate per van e piccoli autocarri, sono macchine completamente autonome con motorizzazione benzina o diesel. LEGGERE e SUPER COMPATTE, non vincolano gli automezzi su cui sono installate e si adattano alle esigenze di spazio dei clienti grazie ai nostri serbatoi modulari.*

WHALE

WHALE-E

SALMON

SALMON-E

MOSES



### TRAILER

Trailer unit, professional trailers approved for road circulation with petrol or diesel engines and versions up to 750 kg or up to 1500 kg at full load. While maintaining the characteristics of the range, these units make it possible not to constrain the load compartment of a vehicle and avoid the traffic restrictions imposed on large vehicles.

*Unità Trailer, rimorchi professionali omologati per la circolazione stradale con motorizzazioni benzina o diesel e versioni fino a 750 kg o fino a 1500 Kg a pieno carico. Pur mantenendo le caratteristiche di gamma, queste unità consentono di non vincolare il vano di carico di un automezzo ed evitano le limitazioni di traffico imposte ai veicoli di grandi dimensioni.*

CTR-C

JTR-C



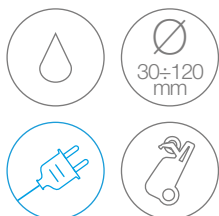

# CJ-1E

Ergonomic handle for easy maneuverability

*Maniglia ergonomica per una pratica movimentazione*



S/S manual hose reel with 30 m 1/4" HP hose.

*Avvolgitubo manuale in acciaio inox con tubo HP 30 m 1/4"*



Handy lance and gun storage

*Pratico alloggiamento della pistola e della lancia*



Can be used vertically or horizontally

*Utilizzabile in verticale o in orizzontale*



## LW-K 250

Pump with 3 integral ceramic pistons. Oil sight glass. Brass pump heads

*Pompa con 3 pistoni in ceramica integrate. Visore livello olio. Testate in ottone*



**GENERAL FEATURES · CARATTERISTICHE GENERALI**

- Sturdy injection-moulded plastic casing
- 4-pole motor (1400 rpm) well oversized and protected with paint
- Comet LW-K type pump (3 integral ceramic pistons and brass pump head) with oil sight glass.
- Self-priming pumps with EASY-START device
- Handy lance and gun storage
- Handle with supports for the power cable and delivery hose
- Easy maintenance by simply removing the front casing
- Big wheels (220 mm Ø) for easy movement up and down steps and over uneven ground
- Pressure gauge
- Built-in professional unloader valve
- DelayedTotalStop
- Pulse System
- Rotary switch
- Motor thermal protection
- S/S manual hose reel with 30 m 1/4" HP hose
- N. 2 1/4" F unblocking nozzles
- Gun with washing lance
- Robuste carenature in materiale plastico stampato ad iniezione
- Motore a 4 poli (1400 giri/min) ampiamente sovradimensionato e protetto da verniciatura
- Pompa COMET tipo LW-K 3 pistoni in ceramica integrale con testata in ottone e visore livello olio.
- Pompe autoadescanti dispositivo EASY-START.
- Pratico alloggiamento della pistola e della lancia
- Manico con supporti di cavo alimentazione e tubo mandata
- Facilità di manutenzione con la semplice rimozione della carenatura frontale
- Ruote di grandi dimensioni (Ø220mm) per una facile movimentazione su gradini e terreni accidentati
- Manometro di pressione
- Valvola di regolazione professionale integrata
- TotalStop ritardato
- Dispositivo Pulse
- Interruttore rotativo
- Protezione termica motore
- Avvolgitubo manuale in acciaio inox con tubo HP 30 m 1/4"
- N. 2 ugelli da spurgo 1/4" F
- Pistola con lancia da lavaggio

**TECHNICAL FEATURES · CARATTERISTICHE TECNICHE**

MODELS MODELLI									
	Ph	V	l/min	bar	MPa	HP	kW	(L x W x H) cm	kg
CJ-1E 12/110	1	230	12	110	11	3,0	2,2	54 x 44 x 68	40

Data refers to standard configurations · Dati riferiti alle unità con dotazione standard

**STANDARD EQUIPMENT · DOTAZIONE STANDARD**





# CJ-2B



## TW PREMIUM

Pump (3 ceramic pistons and brass pump head) with gearbox

*Pompa (3 pistoni in ceramica e testata in ottone) con riduttore di giri*

Honda GX 390 petrol engine with manual recoil

*Motore benzina Honda GX 390 avviamento manuale*



Stainless steel hose reel with 30 m 3/8" + 10 m 3/16" HP hoses

*Avvolgitubo in acciaio inox con tubo HP 30 m 3/8" + tubo HP 10 m 3/16"*



High quality painted steel frame

*Telaio di alta qualità in acciaio verniciato*

2 wheels

*2 ruote*

Gearbox (with 1560 rpm pump)





*Riduttore di giri (con pompa a 1560 rpm)*



## GENERAL FEATURES · CARATTERISTICHE GENERALI

- High quality painted steel frame
- Honda petrol engine with manual recoil
- Comet TW Premium pump (3 ceramic pistons and brass pump head) with gearbox
- 4 wheels of which 2 castors
- No engine-oil safety device (oil-alert)
- Automatic decelerator to reduce RPM in the bypass phase
- Gearbox (with 1560 rpm pump)
- Readily serviceable brass suction filter
- Water suction from external tank option (self-priming pumps)
- Overheating thermostatic valve
- Stainless steel hose reel with 30 m 3/8" + 10 m 3/16" HP hoses
- N.2 nozzles 3/8" F and N. 1 nozzle 1/8" F
- Gun with washing lance
- Telaio di alta qualità in acciaio verniciato
- Motore benzina Honda avviamento manuale
- Pompa Comet TW Premium (3 pistoni in ceramica e testata in ottone) con riduttore di giri
- 4 ruote di cui 2 pivotanti
- Dispositivo di Sicurezza mancanza olio motore
- Deceleratore automatico per la riduzione del numero di giri in fase di by-pass
- Riduttore di giri (con pompa a 1560 rpm)
- Filtro aspirazione in ottone facilmente ispezionabile
- Possibilità di aspirare acqua da serbatoio esterno (pompe autoadescanti)
- Valvola termostatica di protezione da sovratemperatura
- Avvolgitubo in acciaio inox con tubo HP 30 m 3/8" + tubo HP 10 m 3/16"
- N. 2 ugelli da spurgo 3/8" F e N. 1 ugello 1/8" F
- Pistola con lancia da lavaggio

## TECHNICAL FEATURES · CARATTERISTICHE TECNICHE

MODELS MODELLI					
	l/min	bar      MPa	HP      kW	(L x W x H) cm	kg
CJ-2B 32/130	32	130      13	11,7      8,7	90 x 75 x 130	120

Data refers to standard configurations · Dati riferiti alle unità con dotazione standard

## STANDARD EQUIPMENT · DOTAZIONE STANDARD



Gun  
Pistola



Washing lance  
Lancia da lavaggio



N. 2 3/8" F + N. 1 1/8" nozzles  
N. 2 ugelli da spurgo 3/8" F + N. 1 ugello 1/8"



# WHALE

Manual hose guide  
(included in the Plus  
Pulse versions)

*Guida tubo manuale  
(incluso nelle versioni  
Plus Pulse)*

Robust high quality  
manual hose reels

*Avvolgitubo manuali  
robusti di alta qualità*

Modular water tanks

*Serbatoi d'acqua  
modulari*



Lever to unlock HP hose reel (only  
electric version)

*Leva di folle per sbloccare naspo AP  
(solo versione elettrica)*

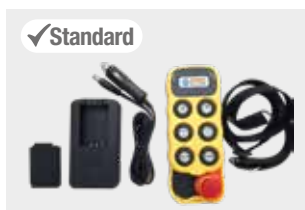

Multi-function remote control ,  
2 batteries, 12-24V charger

*Radiocomando multifunzione, 2  
batterie, caricatore 12-24V*



Pulse system on the pump

*Pulse system sulla pompa*



Easy movement thanks to  
the lower loading pockets

*Facilità di movimento grazie  
alle tasche di carico inferiori*



Suitable for mounting in  
small sized commercial  
vehicles like Fiat Fiorino/  
Doblò or VW Caddy.

*Ideale per veicoli commerciali  
di piccole dimensioni come  
Fiat Fiorino/Doblò o VW  
Caddy.*



✓ Standard



Winter Kit to empty the system with  
compressor  
*Sistema Antigelo per vuotare il sistema  
con compressore*

**GENERAL FEATURES · CARATTERISTICHE GENERALI**

- 24 HP Honda petrol engine
- Comet TW Premium Pump with reduction gearbox
- High-pressure hose reel max. 60 m 1/2" hose
- Manual hose reel with 35m of hose for filling (optional: second HP reel 50m 1/2" or 80 m 3/8")
- Panel with ignition key, hour counter and engine alarms
- Manual regulation by-pass valve, safety valve and pressure gauge
- Remote control 7 functions (9 with electric hose reel optional)
- 50/60 m of 3/8 "or 1/2" high pressure hose (optional)
- 400 or 500 lt modular polyethylene tanks
- Winter kit standard on each machine
- Motore a benzina marca Honda da 24 HP
- Pompa Comet modello TW Premium con riduttore
- Naspo alta pressione manuale max 60 m di tubo da 1/2"
- Naspo manuale completo di 35 m di tubo per riempimento (optional: secondo naspo HP 50m 1/2" o 80 m 3/8")
- Quadro con chiave di accensione, conta ore e allarmi motore
- Valvola by-pass di regolazione manuale, valvola di sicurezza e manometro
- Telecomando 7 funzioni (9 con avvolgitubo elettrico opzionale)
- 50/60 m di tubo alta pressione da 3/8" o 1/2" (optional)
- Serbatoio in polietilene da 400 o 500 lt con serbatoi modulari
- Kit invernale di serie su ogni macchina

**CUSTOMIZED VERSIONS · VERSIONI PERSONALIZZATE**



Standard version  
Versione Standard

A



Version with electric powered hose reel  
Versione con avvolgitubo elettrico

B



Version with 2 HP hose reel HP (electric and manual)  
Versione con 2 avvolgitubo HP (elettrico e manuale)

C

**TECHNICAL FEATURES · CARATTERISTICHE TECNICHE**

MODELS MODELLI											
	l/min	bar	type	HP	kW	cm (L x W x H)	kg	cm (L x W x H)	kg	cm (L x W x H)	kg
Whale 30/250	30	250	Honda	24	17,7	65x102x103	≥ 250	120x102x103	≥ 300	131x102x103	≥ 300
Whale 36/210	36	210	Honda	24	17,7	65x102x103	≥ 250	120x102x103	≥ 300	131x102x103	≥ 300
Whale 43/180	43	180	Honda	24	17,7	65x102x103	≥ 250	120x102x103	≥ 300	131x102x103	≥ 300
Whale 55/160	55	160	Honda	24	17,7	65x102x103	≥ 250	120x102x103	≥ 300	131x102x103	≥ 300

Data refers to standard configurations · Dati riferiti alle unità con dotazione standard

**ACCESSORIES ON REQUEST · ACCESSORI A RICHIESTA**



UNI 45 / STORZ kit for water hydrant connection  
Kit UNI 45 / STORZ per connessione idrante acqua



Gun kit with different type of cleaning lances  
Kit pistola con varie tipologie di lance da lavaggio



Set of pipe unblocking nozzles  
Set ugelli sturatubo



Sludge pump (Venturi) kit  
Kit aspirafango (Venturi)



100 kW-12 VDC auxiliary hot water mobile generator  
Generatore mobile di acqua calda 100 kW-12 VCC ausiliario

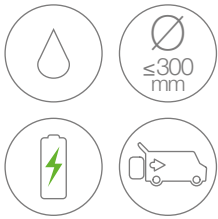

# WHALE



## electric / elettrico

Electric HP reel with winding and unwinding mode

*Naspo HP a motorizzazione elettrica con modalità avvolgi e svolgi*

Manual Hose Guide

*Guida tubo manuale*

Manual heavy duty low pressure hose reel

*Avvolgitubo manuale robusto a bassa pressione*



**PATENTED**



**CPS - Control Power System:**  
High Efficiency, Energy Saving

**CPS - Control Power System:**  
Massima Efficienza, Consumi Ridotti



**NEW**

✓ Standard



Multifunction radio control with coloured display, 2 batteries, 12-24V charger

*Radiocomando multifunzione con display a colori, 2 batterie, caricatore 12-24V*



Pulse system

✓ Standard



Easy handling thanks to the lower loading pockets

*Facilità di movimentazione grazie alle tasche di carico inferiori*

✓ Standard



Winter Kit to empty the system with compressor

*Sistema Antigelo per vuotare il sistema con compressore*



**GENERAL FEATURES · CARATTERISTICHE GENERALI**

- Full Electric machine equipped with a high-performance electric motor managed by an inverter, all powered by a 17.6 kWh lithium battery pack
- Automatic regulation of engine speed based on set pressure and nozzle size to optimize energy consumption and maximize autonomy (patent pending)
- Electrical proportional pressure regulation
- Comet volumetric pump model TW with electric or pulley and belt transmission
- High pressure electric hose reel max 80 m 1/2" hose, complete with manual hose reel guide
- Manual reel with 35 m of filling hose (or optional: second HP reel with max 80 m of 3/8 "or 45 m 1/2" high pressure hose)
- PLC control panel, safety valve and pressure gauge.
- Radio control with display (9 functions)
- Water tank capacity of 400 lt
- Standard Winter kit on each machine
- High pressure pipe meter counter system (optional)
- CPS - Control Power System: Consumption management system based on the required power
- *Attrezzatura Full Electric dotata di un motore elettrico ad alte prestazioni gestito da un inverter, il tutto alimentato da un pacco batterie al litio da 17.6 kWh*
- *Regolazione automatica dei giri motore in funzione della pressione impostata e della misura dell'ugello per ottimizzare i consumi di energia e massimizzare l'autonomia (in attesa di brevetto)*
- *Regolazione elettrica proporzionale della pressione*
- *Pompa volumetrica Comet modello TW con trasmissione elettrica o a cinghia e puleggia*
- *Naspo alta pressione elettrico max 80 m di tubo da 1/2", completo di guida tubo manuale*
- *Naspo manuale completo di 35 m di tubo per riempimento (oppure come optional: secondo naspo HP con max 80 m di tubo alta pressione da 3/8" o max 45 m da 1/2")*
- *Quadro comandi PLC, valvola di sicurezza e manometro.*
- *Radiocomando con schermo (9 funzioni)*
- *Serbatoi da 400 lt*
- *Kit Anti gelo di serie su ogni macchina*
- *Sistema contometri tubo alta pressione (optional)*
- *CPS - Control Power System: Sistema di gestione dei consumi in base alla potenza richiesta*



✓ Standard  
LCD display for machine management.  
*Schermo a colori LCD per gestire la macchina.*

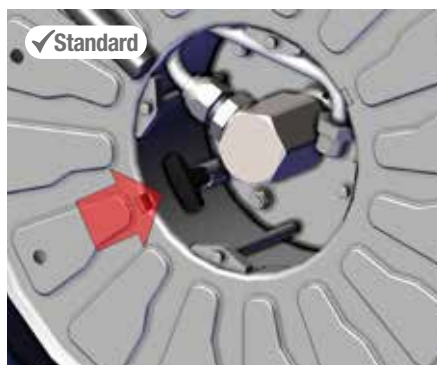

✓ Standard  
Lever to unlock the reel.  
*Leva di folle per sbloccare il naspo.*



17.6 kW lithium batteries. Autonomy 3300 lt at full power. Recharge 0-100% in 3 hours (400V). Normal 220V charging available. Battery charger on request.  
*Batterie al litio 17.6 Kw. Autonomia massima 3300 lt a piena potenza. Ricarica 0-100% in 3.5 ore (400V). Disponibile 220V carica normale. Caricabatteria optional.*

MODELS MODELLI	l/min	bar
Whale-e 30/250	30	250
Whale-e 36/210	36	210
Whale-e 43/180	43	180
Whale-e 55/160	55	160
Whale-e 63/140	63	140

Net weight approximately 450 kg  
*Peso a secco circa 450 kg*

Data refers to standard configurations · *Dati riferiti alle unità con dotazione standard* | Dimensions with 400 lt tank · *Dimensioni comprese di Serbatoio da 400 lt.*

# SALMON



Manual hose guide

*Guida tubo manuale*

Electric powered HP reel with winding and unrolling mode

*Naspo HP a motorizzazione elettrica con modalità avvolgi e svogli*

Robust high quality manual hose reel

*Avvolgitubo manuale robusto di alta qualità*

Modular water tanks

*Serbatoi d'acqua modulari*



Option

**NEW**

Electrically extendable HP hose reel  
*Naspo HP estendibile elettricamente*

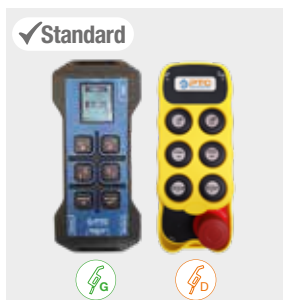

✓ Standard

Multi-function remote control, 2 batteries, 12-24V charger

*Radiocomando multifunzione, 2 batterie, caricatore 12-24V*



✓ Standard

Pulse system (present only in the gasoline version excepting 30/300 and 45/240)

*Pulse system (presente solo nella versione benzina eccetto 30/300 and 45/240)*

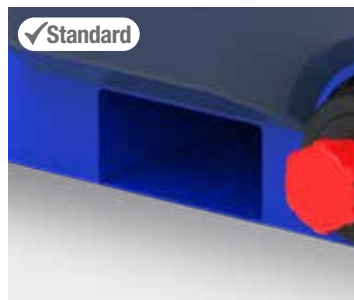

✓ Standard

Easy movement thanks to the lower loading pockets

*Facilità di movimento grazie alle tasche di carico inferiori*



Suitable for mounting in small sized commercial vehicles like Fiat Doblò or VW Caddy.

*Ideale per veicoli commerciali di piccole dimensioni come Fiat Doblò o VW Caddy.*



✓ Standard



Winter Kit to empty the system with compressor  
*Sistema Antigelo per vuotare il sistema con compressore*

### GENERAL FEATURES · CARATTERISTICHE GENERALI

- Vanguard petrol or Kohler diesel engine
- HPP volumetric pump model ET-ETH with pulley and belt transmission
- Electric high pressure hose reel max 80 m of ½" hose
- Manual hose reel with 35m of hose for filling (or second HP reel as optional)
- PLC control panel with hours counter, engine alarms, hose reel and rpm management
- Manual regulation by-pass valve, safety valve and pressure gauge
- Remote control 9 functions
- Second HP reel with max 80 m of 3/8" or max 60 m of ½" high pressure hose (optional)
- 400, 500, 800 or 1000 l tanks capacity with modular tanks (optional)
- Winter kit standard on each machine
- Motore benzina Vanguard o diesel Kohler
- Pompa volumetrica HPP modello ET-ETH con trasmissione a cinghia e puleggia
- Naspo alta pressione elettrico max 80 m di tubo da ½"
- Naspo manuale completo di 35 m di tubo per riempimento (oppure secondo naspo HP come optional)
- Quadro comandi PLC con conta-ore, allarmi motore e gestione giri motore e naspo alta pressione
- Valvola by-pass di regolazione manuale, valvola di sicurezza e manometro
- Radiocomando 9 funzioni
- Secondo naspo HP con max 80 m di tubo alta pressione da 3/8" o max 60 m da ½" (optional)
- Serbatoi da 400, 500, 800 oppure 1000 l con taniche modulari (optional)
- Kit invernale di serie su ogni macchina



LCD color display screen for managing machine  
Schermo a colori LCD per gestire la macchina

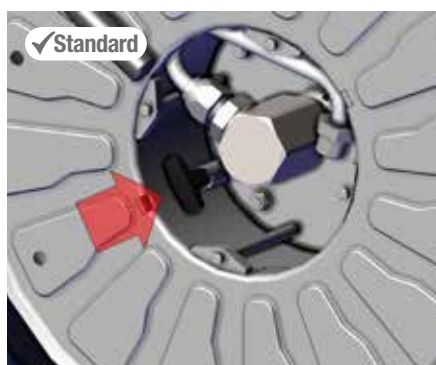

Lever to unlock the reel.  
Leva di folle per sbloccare il naspo.



Standard muffler kit on all models  
Kit marmitta standard su tutti i modelli

### GASOLINE TECHNICAL FEATURES · CARATTERISTICHE TECNICHE BENZINA

MODELS MODELLI				HP	kW		kg		kg		kg
	l/min	bar									
Salmon 30/300	30	300	Vanguard	40	29,8	76x125x120	≥ 370	133x125x120*	≥ 400	167x125x120*	≥ 430
Salmon 45/240	45	240	Vanguard	40	29,8	76x125x120	≥ 370	133x125x120*	≥ 400	167x125x120*	≥ 430
Salmon 60/200	60	200	Vanguard	40	29,8	76x125x120	≥ 370	133x125x120*	≥ 400	167x125x120*	≥ 430
Salmon 75/150	75	150	Vanguard	40	29,8	76x125x120	≥ 370	133x125x120*	≥ 400	167x125x120*	≥ 430

Data refers to standard configurations · Dati riferiti alle unità con dotazione standard | \* Dimensions including modular tanks · Dimensioni comprese di Serbatoi modulari

### DIESEL TECHNICAL FEATURES · CARATTERISTICHE TECNICHE DIESEL

MODELS MODELLI				HP	kW		kg		kg		kg
	l/min	bar									
Salmon 35/250	35	250	Kohler	26	19	76x125x120	≥ 370	133x125x120*	≥ 400	167x125x120*	≥ 430
Salmon 45/200	45	200	Kohler	26	19	76x125x120	≥ 370	133x125x120*	≥ 400	167x125x120*	≥ 430
Salmon 60/150	60	150	Kohler	26	19	76x125x120	≥ 370	133x125x120*	≥ 400	167x125x120*	≥ 430

Data refers to standard configurations · Dati riferiti alle unità con dotazione standard | \* Dimensions including modular tanks · Dimensioni comprese di Serbatoi modulari

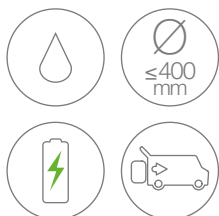

# SALMON electric / elettrico



Electric HP reel with winding and unwinding mode

*Naspo HP a motorizzazione elettrica con modalità avvolgi e svogli*

Manual Hose Guide

*Guida tubo manuale*

Manual heavy duty hose reel

*Avvolgitubo manuale robusto di alta qualità*



**PATENTED**



**CPS - Control Power System:**  
High Efficiency, Energy Saving

**CPS - Control Power System:**  
*Massima Efficienza, Consumi Ridotti*



✓ Standard



Multifunction radio control, 2 batteries, 12-24V charger

*Radiocomando multifunzione, 2 batterie, caricatore 12-24V*

✓ Standard



Pulse system

✓ Standard

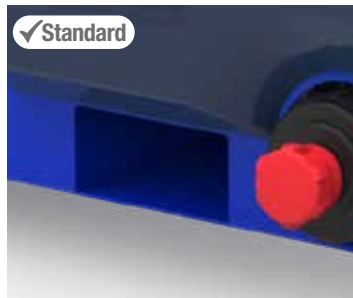

Easy movement thanks to lower loading sheaths

*Facilità di movimento grazie alle tasche di carico inferiori*



✓ Standard



Winter Kit to empty the system with compressor

*Sistema Antigelo per vuotare il sistema con compressore*

**GENERAL FEATURES · CARATTERISTICHE GENERALI**

- Full Electric machine equipped with a high-performance electric motor with direct connection to the pump managed by an inverter, all powered by a 30kWh lithium battery pack IP65
- Automatic regulation of engine speed based on set pressure and nozzle size to optimize energy consumption and maximize autonomy
- High pressure pipe meter counter system
- Electrical proportional pressure regulation (patent pending)
- HPP volumetric pump model ET-ETH with direct transmission
- High pressure electric hose reel max 80m ½” hose.
- Manual reel with 35 m of filling hose (or optional: second HP reel with max 80 m of 3/8 “or 45 m ½” high pressure hose)
- PLC control panel, safety valve and pressure gauge
- Radio control with display (9 functions)
- Water tank capacity of 500 lt
- Standard winter kit on every machine
- CPS - Control Power System: Consumption management system based on the required power
- *Attrezzatura Full Electric dotata di un motore elettrico ad alte prestazioni con collegamento diretto alla pompa gestito da un inverter, il tutto alimentato da un pacco batterie al litio da 30kWh IP65*
- *Regolazione automatica dei giri motore in funzione della pressione impostata e della misura dell’ugello per ottimizzare i consumi di energia e massimizzare l’autonomia*
- *Sistema contametri tubo alta pressione*
- *Regolazione elettrica proporzionale della pressione (in attesa di brevetto)*
- *Pompa volumetrica HPP modello ET-ETH con trasmissione diretta.*
- *Naspo alta pressione elettrico max 80 m di tubo da ½”.*
- *Naspo manuale completo di 35 m di tubo per riempimento (oppure come optional: secondo naspo HP con max 80 m di tubo alta pressione da 3/8” o max 45 m da ½”)*
- *Quadro comandi PLC, valvola di sicurezza e manometro*
- *Radiocomando con schermo (9 funzioni)*
- *Serbatoi da 500 lt*
- *Kit invernale di serie su ogni macchina*
- *CPS - Control Power System: Sistema di gestione dei consumi in base alla potenza richiesta*



✓ Standard  
LCD color display for machine management.  
Schermo a colori LCD per gestire la macchina.

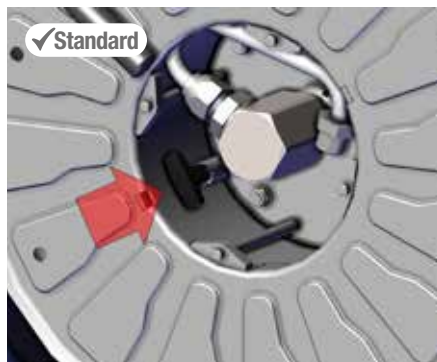

✓ Standard  
Lever to unlock the reel.  
Leva di folle per sbloccare il naspo.



30 kW lithium batteries IP65. Theoretical autonomy 4500 lt at full power. Recharge 0-100% in 4 hours (400V). Normal 220V charging available.  
Batterie al litio 30 Kw IP65. Autonomia teorica 4500 lt a piena potenza. Ricarica 0-100% in 4 ore (400V). Disponibile 220V carica normale.

MODELS MODELLI			
	l/min	bar	
Salmon-e 30/300	30	300	Net weight approximately 850 kg Peso a secco circa 850 kg
Salmon-e 45/240	45	240	
Salmon-e 60/200	60	200	
Salmon-e 75/150	75	150	

Data refers to standard configurations · Dati riferiti alle unità con dotazione standard | \* Dimensions with modular tanks · Dimensioni comprese di Serbatoi modulari

# MOSES

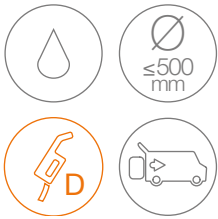

90°+180° pivot hydraulic hose reel

Avvolgitubo idraulico girevole 90° + 180°



Modular water tanks  
Serbatoi modulari



✓ Standard



Multi-function remote control, 2 batteries, 12-24V charger

Radiocomando multifunzione, 2 batterie, caricatore 12-24V

✓ Standard



Pulse system  
Pulse system

✓ Standard



Easy movement thanks to the lower loading pockets

Facilità di movimento grazie alle tasche di carico inferiori



Suitable from medium/large size of commercial Van like Ducato, Transit Custom, Vito, VW Transporter

Adatto a medie / grandi dimensioni di veicoli commerciali come Ducato, Transit Custom, Vito, VW Transporter



✓ Standard



Winter Kit to empty the system with compressor

Sistema Antigelo per vuotare il sistema con compressore

**GENERAL FEATURES · CARATTERISTICHE GENERALI**

- Liquid cooled Yanmar diesel engine, with electric starter
- HPP pump model ET-ETH or ELS with pulley and belt transmission
- 90° + 180° pivot hydraulic high pressure hose reel with max capacity 80m of 1/2" hose
- Manual hose reel complete with 35 m of low pressure hose for filling (optional: second HP reel 45 m 1/2" or 50 m 3/8")
- PLC control panel for engine and operations management (only on Stage V models)
- Manual pressure regulating valve with automatic bypass
- Remote control 9 functions
- Automatic hose guide kit (optional)
- 50/60/80 m di tubo HP da 3/8", 1/2" or 3/4 "high pressure hose (optional)
- 500, 800 or 1000 l tanks capacity with modular tanks (optional)
- Winter kit standard on each machine
- Motore diesel Yanmar raffreddato a liquido, con avviamento elettrico
- Pompa volumetrica HPP modello ET-ETH o ELS con trasmissione a cinghia e puleggia
- Naspo alta pressione idraulico pivot 90° + 180° con capacità max 80m di tubo da 1/2"
- Naspo manuale completo di 35 m di tubo bassa pressione per riempimento (optional: secondo naspo HP 45 m 1/2" o 50 m 3/8")
- Quadro comandi PLC per la gestione del motore e delle operazioni di lavoro
- Valvola di regolazione della pressione manuale con bypass automatico
- Radiocomando 9 funzioni
- Guida tubo a movimentazione automatica (optional)
- 50/60/80 m di tubo alta pressione da 3/8", 1/2" o 3/4" (optional)
- Serbatoi da 500, 800 o 1000 l con taniche modulari (optional)
- Kit invernale di serie su ogni macchina



LCD display colour screen for managing machine  
Schermo a colori LCD per gestire la macchina



Neutral free wheel lever to unlock the reel  
Leva di folle per sbloccare il naspo



Manual or automatic hose guide  
Avvolgitubo manuale oppure automatico

**TECHNICAL FEATURES · CARATTERISTICHE TECNICHE**

MODELS MODELLI											
	l/min	bar	type	HP	kW	cm (L x W x H)	kg	500 lt	kg	800 lt	kg
Moses 60/200	60	200	Yanmar	37	27,5	107x127x110	≥ 625	170x127x110*	≥ 700	198x127x110	≥ 720
Moses 75/150	75	150	Yanmar	37	27,5	107x127x110	≥ 625	170x127x110*	≥ 700	198x127x110	≥ 720
Moses XL 60/250	60	250	Yanmar	48	35,5	107x127x110	≥ 725	170x127x110*	≥ 800	198x127x110	≥ 820
Moses XL 75/210	75	210	Yanmar	48	35,5	107x127x110	≥ 725	170x127x110*	≥ 800	198x127x110	≥ 820
Moses XL 80/180	80	180	Yanmar	48	35,5	107x127x110	≥ 625	170x127x110*	≥ 700	198x127x110	≥ 720
Moses XL 102/150	102	150	Yanmar	48	35,5	107x127x110	≥ 725	170x127x110*	≥ 800	198x127x110	≥ 820

Data refers to standard configurations · Dati riferiti alle unità con dotazione standard | \* Dimensions including modular tanks · Dimensioni comprese di Serbatoi modulari

**ACCESSORIES ON REQUEST · ACCESSORI A RICHIESTA**



UNI 45 / STORZ kit for water hydrant connection  
Kit UNI 45 / STORZ per connessione idrante acqua



Gun kit with different type of cleaning lances  
Kit pistola con varie tipologie di lance da lavaggio



Set of pipe unblocking nozzles  
Set ugelli sturatubo



Sludge pump (Venturi) kit  
Kit aspirafango (Venturi)



100 kW-12 VDC auxiliary hot water mobile generator  
Generatore mobile di acqua calda 100 kW-12 VCC ausiliario

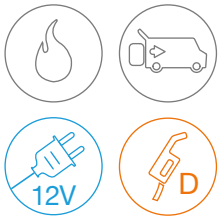

# HOT WATER KIT

High pressure boiler up to 350 bar, supplied with the PTC machine  
*Caldaia alta pressione fino a 350 bar, fornita con la macchina PTC*

## WHALE



## SALMON



## MOSES

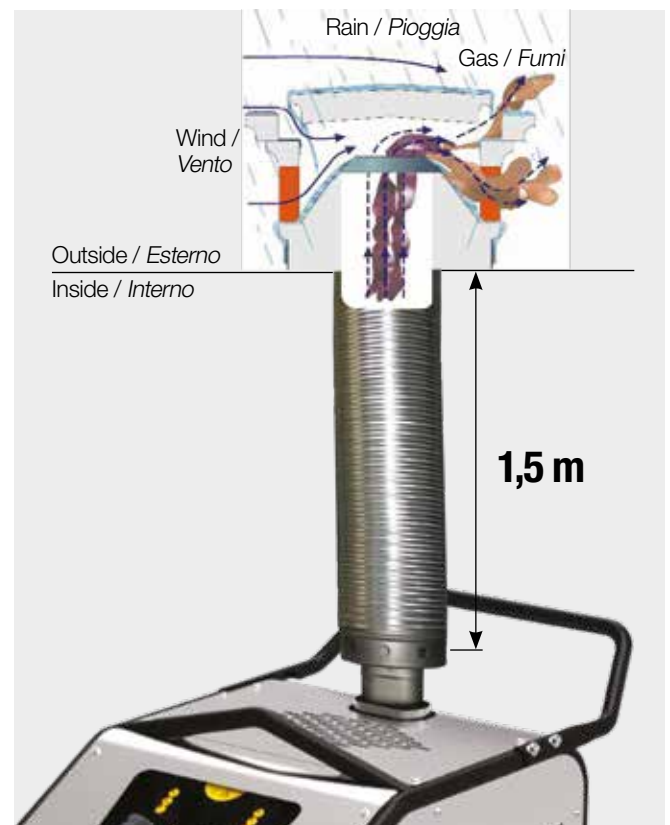
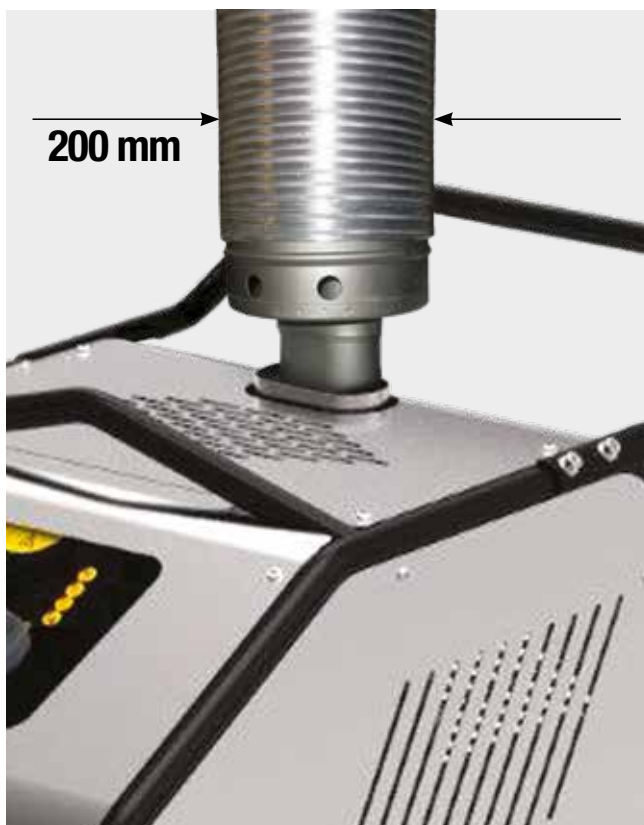

Boiler 350 bar 12 V complete with flue gas outlet and connection to Canaljet PTC equipment. In connection with the equipment the maximum temperature is 70 °C

*Caldaia 350 bar 12 V completa di scarico fumi e collegamento ad attrezzatura Canaljet PTC. In collegamento con l'attrezzatura la temperatura massima è 70 °C*

Easy to handle  
*Facilità di movimento*

Central bar for vertical lifting  
*Gancio per sollevamento verticale*

Professional control panel  
*Quadro comandi professionale*

Foamed-acting pneumatic wheels  
*Ruote effetto pneumatico*

Stainless-steel cladding panel  
*Pannello di rivestimento in acciaio inox*

I/min	DELTA T °C
11	111
13	103
15	93
18	75
21	63
25	55
30	45
35	35

**GENERAL FEATURES · CARATTERISTICHE GENERALI**

- Easy to handle
- Professional control panel
- Central bar for vertical lifting
- Sturdy frame painted with anti-corrosive treatment, Stainless-steel cladding panel
- Foamed-acting pneumatic wheels
- Connection hose (SAE 100 - 2 mt)
- Fuel tank with level float and fill up filter
- Steam operation
- Flow-switch controlled burner
- Professional safety valve
- Boiler thermal protection
- Flame control
- Electronic temperature setting system with constant water temperature
- Delayed burner start
- *Facilità di movimento*
- *Quadro comandi professionale*
- *Gancio per sollevamento verticale*
- *Robusto telaio verniciato con trattamenti anticorrosivi, pannello di rivestimento in acciaio inox*
- *Ruote effetto pneumatico*
- *Tube di collegamento (SAE 100 - 2 mt)*
- *Serbatoio gasolio, con galleggiante di livello e filtro di riempimento*
- *Funzionamento a vapore*
- *Bruciatore azionato da Flussostato*
- *Valvola di sicurezza professionale*
- *Protezione termica della caldaia*
- *Controllo fiamma*
- *Sistema elettronico di regolazione della temperatura, con basso pendolamento del valore impostato*
- *Partenza ritardata del bruciatore*

**TECHNICAL FEATURES · CARATTERISTICHE TECNICHE**

MODELS MODELLI											
	Ph	V(A)	Hz	l/h	bar	kW	°C	lt	kg/h	cm (L x W x H)	kg
Hot Box 25/350	-	12 (26)	-	1500	350	0,25	90 > 140	20	8,3	76x77x96	110



# CTR-C

**European homologation - Approved for road transport, category O2, max 750 kg. Only driving licence B required (750 kg)**  
**Omologazione Europea - Omologato per il trasporto stradale, categoria O2, max 750 kg. Utilizzabile con patente B (≤ 750 kg)**

Robust high quality manual high and low pressure hose reel

*Robusto avvolgitubo manuale di alta e bassa pressione di alta qualità*



New design with ABS cover and key-lock system

*Nuovo design con coperchio in ABS e sistema di chiusura a chiave*



Integrated water tanks for comfortable drive and more stability

*Serbatoi acqua integrati per maggior stabilità e comfort alla guida*



Remote control 7 functions (9 with electric hose reel optional) + control panel

*Telecomando 7 funzioni (9 con avvolgitubo elettrico opzionale) + pannello di controllo remoto*



**GENERAL FEATURES · CARATTERISTICHE GENERALI**

- Single axle trailer with rear lights and reflectors, automatic reverse gear, parking brakes, ABS and Mudguards
- Towing eye for a 50 mm diam. sphere type
- 2x200 l water tanks, fuel tank 43 lt
- Petrol engine Honda or Kohler diesel with electric start
- TW Premium model Comet pump with reducer
- Manual high pressure hose reel max 50 m of ½” hose
- Manual hose reel with 35 m of hose for filling
- Engine panel with ignition key, hour counter, engine alarms and manual accelerator
- Manual regulation by-pass valve, safety valve and pressure gauge
- Manual 2-way ON / OFF valve for work operations
- Rotating beacon light and practical housings for lance
- 50m of ½” high pressure hose (optional)
- Manual hose guide (optional)
- Working light (optional)
- Electric hp hose reel (optional)
- Carrello monoasse con luci posteriori e riflettori, retromarcia automatica, freno di stazionamento, ABS e parafanghi
- Occhiello sferico di traino diametro 50 mm
- Tanica acqua 2 x 200 litri, serbatoio carburante 43 lt
- Motore a benzina Honda o Kohler diesel con avviamento elettrico
- Pompa Comet modello TW Premium con riduttore
- Naspo alta pressione manuale max 50 m di tubo da ½”
- Naspo manuale di 35 m di tubo per riempimento
- Quadro motore con chiave di accensione, contaore, allarmi motore e acceleratore manuale
- Valvola by-pass di regolazione manuale, valvola di sicurezza e manometro
- Valvola 2 vie ON/OFF manuale per operazioni di lavoro
- Girofaro e pratici alloggiamenti per lancia
- 50m di tubo alta pressione da ½” (optional)
- Guida tubo manuale (optional)
- Faro lavoro (optional)
- Avvolgitubo elettrico alta pressione (optional)



“PLUS” version, manual tube guide, high pressure tube, radio control , Pulse system

Versione “PLUS”, guida-tubo manuale, tubo alta pressione, radiocomando, sistema Pulse



**GASOLINE TECHNICAL FEATURES · CARATTERISTICHE TECNICHE BENZINA**

MODELS MODELLI	l/min	bar	type	HP	kW	400 lt	cm (L x W x H)	kg
CTR-C 43/180	43	180	Honda	24	17,7		304,5x139x119	≥ 450
CTR-C 55/160	55	160	Honda	24	17,7		304,5x139x119	≥ 450

Data refers to standard configurations / Dati riferiti alle unità con dotazione standard.

**DIESEL TECHNICAL FEATURES · CARATTERISTICHE TECNICHE DIESEL**

MODELS MODELLI	l/min	bar	type	HP	kW	400 lt	cm (L x W x H)	kg
CTR-C 20/350	20	350	Kohler	26	19		304,5x139x119	≥ 500
CTR-C 60/150	60	150	Kohler	26	19		304,5x139x119	≥ 500

Data refers to standard configurations / Dati riferiti alle unità con dotazione standard.

**ACCESSORIES ON REQUEST · ACCESSORI A RICHIESTA**



UNI 45 / STORZ kit for water hydrant connection  
Kit UNI 45 / STORZ per connessione idrante acqua



Gun kit with different type of cleaning lances  
Kit pistola con varie tipologie di lance da lavaggio



Set of pipe unblocking nozzles  
Set ugelli sturatubo



Sludge pump (Venturi) kit  
Kit aspirafango (Venturi)



100 kW-12 VDC auxiliary hot water mobile generator  
Generatore mobile di acqua calda 100 kW-12 VCC ausiliario

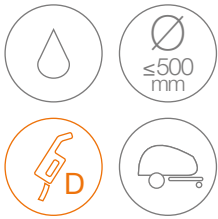

# JTR-C

**European homologation - Approved for road transport, 1050 kg or 1500 kg GVW.**  
*Omologazione Europea - Omologato per il trasporto stradale, 1050 kg o 1500 kg di GVW massimo.*



Robust high quality hydraulic HP hose reel

*Avvolgitubo idraulico HP robusto di alta qualità*

Heavy duty single axle trailer complete with high load capacity tires

*Rimorchio monoasse per utilizzi gravosi completo di pneumatici ad elevata capacità di carico*



Front and rear cover and watertank in Fiberglass

*Copertura anteriore e posteriore e serbatoio dell'acqua in vetroresina*



Multifunction radio control, LCD color display

*Radiocomando multifunzione, schermo a colori LCD*



**HPP ET**  
 Pump on / Pompa su:  
 75/210, 57/250







**GENERAL FEATURES · CARATTERISTICHE GENERALI**

- Single axle trailer with rear lights and reflectors, automatic reverse gear, parking brakes, high load tyres, ABS and Mudguards
- Towing eye for a 50 mm diam. sphere type
- Water cooled Yanmar diesel engine with electric starter
- HPP pump model ET with pulley and belt transmission
- Hydraulic high pressure hose reel max 100m of 1/2" hose
- Manual hose reel with 35m of hose for refill
- Front/Rear cover and water tank of 600l capacity in fiberglass, fuel tank 35 lt
- Manual pressure regulator by-pass valve, safety valve and pressure gauge
- 50/60/80 m of 1/2 "or 3/4" high pressure hose (optional)
- Working light (optional)
- Pulse system
- Remote control 9 functions
- Carrello monoasse con luci posteriori e riflettori, retromarcia automatica, freno di stazionamento, pneumatici per carichi elevati, ABS e parafanghi
- Occhiello sferico di traino diametro 50 mm
- Motore diesel Yanmar raffreddato ad acqua con avviamento elettrico
- Pompa volumetrica HPP modello ET con trasmissione a cinghia e puleggia
- Avvolgitubo idraulico alta pressione max 100m di tubo da 1/2"
- Avvolgitubo manuale con 35m di tubo per ricarica
- Coperchio anteriore / posteriore e serbatoio dell'acqua da 600 litri in vetroresina, serbatoio carburante 35 lt
- Valvola by-pass di regolazione manuale, valvola di sicurezza e manometro
- 50/60/80 m di tubo alta pressione da 1/2" o 3/4" (optional)
- Faro di lavoro (optional)
- Sistema Pulse
- Radiocomando 9 funzioni



**TECHNICAL FEATURES · CARATTERISTICHE TECNICHE**

MODELS MODELLI	 l/min	 bar	type	 HP	kW	 600 lt	cm (L x W x H)	kg
JTR-C 60/200	60	200	Yanmar	37	27,5		345x164x158	≥ 900
JTR-C 75/150	75	150	Yanmar	37	27,5		345x164x158	≥ 900
JTR-C 60/250	60	250	Yanmar	48	35,5		345x164x158	≥ 900
JTR-C 75/210	75	210	Yanmar	48	35,5		345x164x158	≥ 900
JTR-C 80/180	80	180	Yanmar	48	35,5		345x164x158	≥ 900
JTR-C 102/150	102	150	Yanmar	48	35,5		345x164x158	≥ 900

Data refers to standard configurations / Dati riferiti alle unità con dotazione standard.

**ACCESSORIES ON REQUEST · ACCESSORI A RICHIESTA**



UNI 45 / STORZ kit for water hydrant connection  
Kit UNI 45 / STORZ per connessione idrante acqua



Gun kit with different type of cleaning lances  
Kit pistola con varie tipologie di lance da lavaggio



Set of pipe unblocking nozzles  
Set ugelli sturatubo



Sludge pump (Venturi) kit  
Kit aspirafango (Venturi)



100 kW-12 VDC auxiliary hot water mobile generator  
Generatore mobile di acqua calda 100 kW-12 VCC ausiliario



# Vacuum & Combined

- Emptying chemical toilets, train and airplane toilets
  - Collection of used oils from restaurants and fried food stores
  - Vacuum suction for multiple uses on construction sites
  - Engine oil suction on boats, without the need to lift or remove the engine
  - Unblocking of pipes and drainage
  - Cleaning of pipes, drains, facades, floors, street furniture
- *Svuotamento bagni chimici, toilette di treni e aerei*
  - *Raccolta di oli usati da ristoranti e negozi di cibi fritti*
  - *Aspirazione sottovuoto per usi molteplici su cantieri edili*
  - *Aspirazione oli motore su barche, senza necessità di sollevare o rimuovere il motore*
  - *Disotturazione tubature e stasamento scarichi*
  - *Pulizia condotte, caditoie, facciate, pavimentazioni, arredi urbani*





## Vacuum & Combined units

### *Unità di aspirazione e lavaggio*

Vortex autonomous vacuum suction units for the recovery and transport of non-hazardous liquids, sewage residues, sludge, semi-solids, oils. etc.

COMBI versions with high pressure washing system.

*Vortex unità autonome di aspirazione sottovuoto per il recupero e trasporto di liquidi non pericolosi, residui fognari, fanghi, semi-solidi, oli. etc.*

*Versioni COMBI con sistema di lavaggio ad alta pressione.*

#### CONFIGURATIONS · CONFIGURAZIONI

#### UNITS · UNITÀ



### SKID

The Skid configuration permits use on platforms and roll-offs without any changes having to be made to the vehicle. These units are easy to transport and fully independent.

*La configurazione Skid permette l'installazione dell'unità su pianali e scarrabili senza richiedere alcuna modifica all'automezzo. Queste unità sono facilmente trasportabili e completamente autonome.*

VORTEX 400-800-1000 COMPACT

VORTEX 1000 SKID

VORTEX COMBI SEWER

VORTEX COMBI-E

VORTEX COMBI CLEANING



# VORTEX 400 · 800 · 1000

## COMPACT

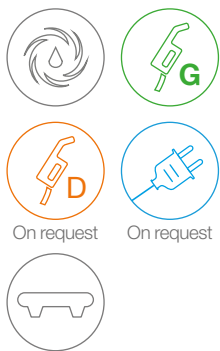

On request

On request

Compact and robust stainless steel vacuum tank

*Cisterna in acciaio inox per il vuoto robusta e compatta*

Manual loading and discharge brass valve

*Valvola di carico e scarico manuale in ottone*



Easy movement thanks to the compact frame and lower loading pockets

*Facile movimento grazie al telaio compatto e alle tasche di carico inferiori*



Double level indicator

*Doppio indicatore di livello*



Hatchway for tank cleaning and inspection

*Boccaporto frontale per pulizia e ispezione cisterna*



**GENERAL FEATURES · CARATTERISTICHE GENERALI**

- Vacuum-resistant stainless steel tank
- Handling with forks
- Honda petrol engine, Yanmar Diesel Engine, or electric motor
- Professional vacuum pump with belt and pulley transmission
- Motor panel with electric start
- 5 m of suction hose Ø 60 mm with quick couplings
- Stainless steel tank, overflow valve, safety valve +0.5 bar, double level indicator, manual fill and drain valve, reverse decompressor
- Cisterna in acciaio inox resistente al vuoto
- Movimentazione con forche
- Motore a benzina Honda, motore Diesel Yanmar o motore elettrico
- Pompa da vuoto professionale con trasmissione cinghia e puleggia
- Quadro motore con avviamento elettrico
- 5 m di tubo di aspirazione Ø 60 mm con attacchi rapidi
- Cisterna in acciaio inox, valvola di troppo pieno, valvola sicurezza +0,5 bar, doppio indicatore di livello, valvola di scarico e carico manuale, inversione decompressore

**CUSTOMIZED VERSIONS · VERSIONI PERSONALIZZATE**



Diesel version  
Versione Diesel





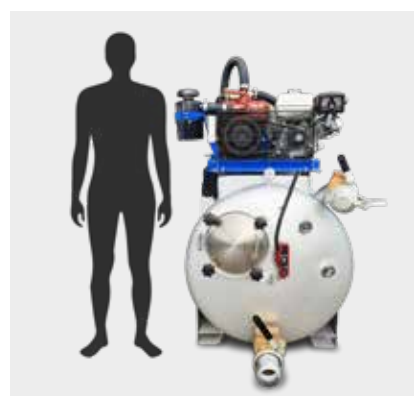

Version with electric motor  
Versione con motore elettrico



Real dimensions  
Dimensioni reali

**TECHNICAL FEATURES · CARATTERISTICHE TECNICHE**

MODELS MODELLI	 l/min	 lt	 HP	 kW	 cm (L x W x H)	 kg
Vortex 400	1260	400	4,8	3,6	75x155x150	≥ 300
Vortex 800	2750	800	8,5	6,3	110x146x190	≥ 400
Vortex 1000	3600	1000	11,8	8,8	100x180x180	≥ 450

Data refers to standard configurations. Available on request with diesel/hydraulic/electric motor and with different volumes tanks · Dati riferiti alle unità con dotazione standard. Disponibile su richiesta con motore diesel/idraulico/elettrico e con cisterne di volumi differenti

**STANDARD ACCESSORIES · ACCESSORI STANDARD**



5 m hose Ø 60 mm for suction with quick coupling  
5 mt tubo Ø 60 mm per l'aspirazione con innesto rapido

**ACCESSORIES ON REQUEST · ACCESSORI A RICHIESTA**



PVC suction rigid tip Ø 60 mm with valve  
Pescante a puntale rigido in PVC Ø 60 mm per aspirazione con valvola



Multifunction radio control for remote control (only ON-OFF)  
Radio comando multifunzione per comando a distanza (solo ON-OFF)

# VORTEX 1000

## SKID



On request

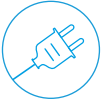

On request



Compact and robust stainless steel vacuum tank

*Cisterna in acciaio inox per il vuoto robusta e compatta*

Easy movement thanks to the compact frame and lower loading pockets

*Facile movimento grazie al telaio compatto e alle tasche di carico inferiori*

Manual loading and discharge brass valve

*Valvola di carico e scarico manuale in ottone*



Double level indicator and vacuum pressure gauge

*Doppio indicatore di livello e manovuotometro*



**GENERAL FEATURES · CARATTERISTICHE GENERALI**

- Honda gasoline engines, Yanmar Diesel engines or electric motor
- Sliding vanes professional vacuum pumps
- Hook handling with belts or handling with fork lift
- Stainless steel tank 1000 lt, overflow valve, safety valve +0.5 bar, double level indicator, manual fill and drain valve, reverse decompressor
- 5 m hose Ø 80 mm, for suction with quick coupling
- Stainless steel frame
- *Motori benzina Honda, motori Yanmar Diesel o motori elettrici*
- *Pompe da vuoto professionali a palette*
- *Movimentazione a gancio con fasce o con sollevatore a forche*
- *Cisterna in acciaio inox 1000 lt, valvola di troppo pieno, valvola sicurezza +0,5 bar, doppio indicatore di livello, valvola di scarico e carico manuale, inversione decompressore*
- *5 m tubo Ø 80 mm, per l'aspirazione con innesto rapido*
- *Telaio in acciaio inox*

**CUSTOMIZED VERSIONS · VERSIONI PERSONALIZZATE**



Diesel version  
Versione Diesel







Version with electric motor  
Versione con motore elettrico



Trailer version  
Versione con rimorchio

**TECHNICAL FEATURES · CARATTERISTICHE TECNICHE**

MODELS MODELLI	 l/min	 lt	 HP	kW	 cm (L x W x H)	 kg
Vortex 1000 G	3600	1000	11,8	8,8	121x230x140	≥ 520
Vortex 1000 D	3600	1000	9,3	7	121x230x140	≥ 520
Vortex 1000 E	3600	1000	10	7,5	121x230x150	≥ 520

Data refers to standard configurations. Available on request with diesel/hydraulic/electric motor and with different volumes tanks · *Dati riferiti alle unità con dotazione standard. Disponibile su richiesta con motore diesel/idraulico/elettrico e con cisterne di volumi differenti*

**STANDARD ACCESSORIES · ACCESSORI STANDARD**



5 m hose Ø 80 mm for suction with quick coupling  
5 mt tubo Ø 80 mm per l'aspirazione con innesto rapido

**ACCESSORIES ON REQUEST · ACCESSORI A RICHIESTA**



PVC suction rigid tip Ø 80 mm with valve  
Pescante a puntale rigido in PVC Ø 80 mm per aspirazione con valvola



Multifunction radio control for remote control (only ON-OFF)  
Radio comando multifunzione per comando a distanza (solo ON-OFF)

# VORTEX COMBI SEWER

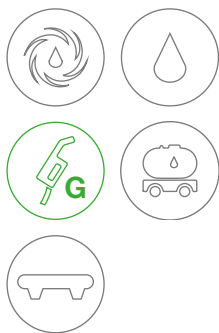

Manual loading and discharge brass valve

*Valvola di carico e scarico manuale in ottone*



Double level indicator

*Doppio indicatore di livello*



Compact and robust stainless steel vacuum tank

*Cisterna in acciaio inox per il vuoto robusta e compatta*



Easy movement thanks to the lower loading pockets

*Facile movimento grazie alle tasche di carico inferiori*

✓ **Standard**

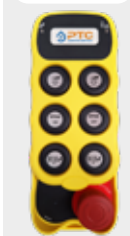

Multi-function radio control for remote control (only Built-in, Vortex on request)

*Radio comando multi-funzione per comando a distanza (solo ON-OFF, Vortex su richiesta)*



**GENERAL FEATURES · CARATTERISTICHE GENERALI**

- High quality steel frame with forklift pockets
- Gasoline engines Honda 24 HP and Vanguard 40 HP
- Sliding vanes professional vacuum pumps
- Forced oil lubrication
- TW Premium Comet HP water pumps or HPP ET/ETH
- Stainless steel tank, overflow valve, safety valve +0.5 bar, double level indicator, manual fill and drain valve, reverse decompressor
- 400/500 l polyethylene water tank
- Remote control 7/9 functions (ON/OFF, By-Pass, ± RPM)
- HP manual or electric hose reel
- 5 m hose Ø 80 mm, for suction with quick coupling
- Ø 80 mm suction rigid tip
- Telaio in acciaio di alta qualità in con predisposizione per sollevamento tramite forche muletto
- Motori benzina Honda 24 HP and Vanguard 40 HP
- Pompe da vuoto professionali a palette
- Lubrificazione forzata
- Pompe HP Comet TW Premium o HPP ET/ETH
- Cisterna in acciaio inox, valvola di troppo pieno, valvola sicurezza +0,5 bar, doppio indicatore di livello, valvola di scarico e carico manuale, inversione decompressore
- Cisterna acqua in polietilene 400/500 l
- Radiocomando 7/9 funzioni (ON/OFF, By-Pass, ± RPM)
- Naspo HP manuale o elettrico
- 5 m tubo Ø 80 mm, per l'aspirazione con innesto rapido
- Puntale di aspirazione Ø 80 mm



VORTEX COMBI 400 WHALE



VORTEX COMBI 1000 WHALE



VORTEX COMBI 400 SALMON

**TECHNICAL FEATURES · CARATTERISTICHE TECNICHE**

MODELS MODELLI	l/min - bar	l/min	lt	lt	HP	kW	cm (L x W x H)	kg
Vortex Combi 400 Whale	55 - 160	1260	500	400	4,8 - 24	3,6 - 17,7	185 x 150 x 160	≥ 650
Vortex Combi 1000 Whale	55 - 160	3600	500	1000	11,8 - 24	8,8 - 17,7	210 x 190 x 144	≥ 800
Vortex Combi 400 Salmon	60 - 200	1260	400/500	400	4,8 - 40	3,6 - 29,8	245 x 145 x 130	≥ 720
	30 - 300	1260	400/500	400	4,8 - 40	3,6 - 29,8	245 x 145 x 130	≥ 720
Vortex Combi 1000 Salmon	60 - 200	3600	400/500	1000	11,8 - 40	8,8 - 29,8	215 x 178x 140	≥ 880
	30 - 300	3600	400/500	1000	11,8 - 40	8,8 - 29,8	215 x 178x 140	≥ 880

Data refers to standard configurations. Available on request with diesel/hydraulic/electric motor and with different volumes tanks · Dati riferiti alle unità con dotazione standard. Disponibile su richiesta con motore diesel/idraulico/elettrico e con cisterne di volumi differenti

**STANDARD ACCESSORIES · ACCESSORI STANDARD**



5 m hose Ø 80 mm for suction with steel quick coupling  
5 mt tubo Ø 80 mm per l'aspirazione con innesto rapido inox



5 m hose Ø 100 mm for suction with steel quick coupling for unload tank  
5 mt tubo Ø 100 mm per l'aspirazione con innesto rapido inox per scarico cisterna



PVC suction rigid tip Ø 80 mm with valve  
Pescante a puntale rigido in PVC Ø 80 mm per aspirazione con valvola



UNI 45 / STORZ kit for water hydrant connection  
Kit UNI 45 / STORZ per connessione idrante acqua

**ACCESSORIES ON REQUEST · ACCESSORI A RICHIESTA**

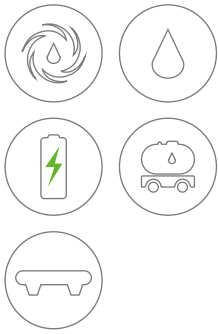

# VORTEX COMBI

## electric / elettrico

**PATENTED**



**CPS - Control Power System:**  
High Efficiency, Energy Saving

**CPS - Control Power System:**  
Massima Efficienza, Consumi Ridotti



Honda electric motor with rechargeable lithium-ion battery

*Motore elettrico Honda con batteria ricaricabile agli Ioni di Litio*



Manual loading and discharge brass valve

*Valvola di carico e scarico manuale in ottone*



Double level indicator

*Doppio indicatore di livello*

Compact and robust stainless steel vacuum tank

*Cisterna in acciaio inox per il vuoto robusta e compatta*

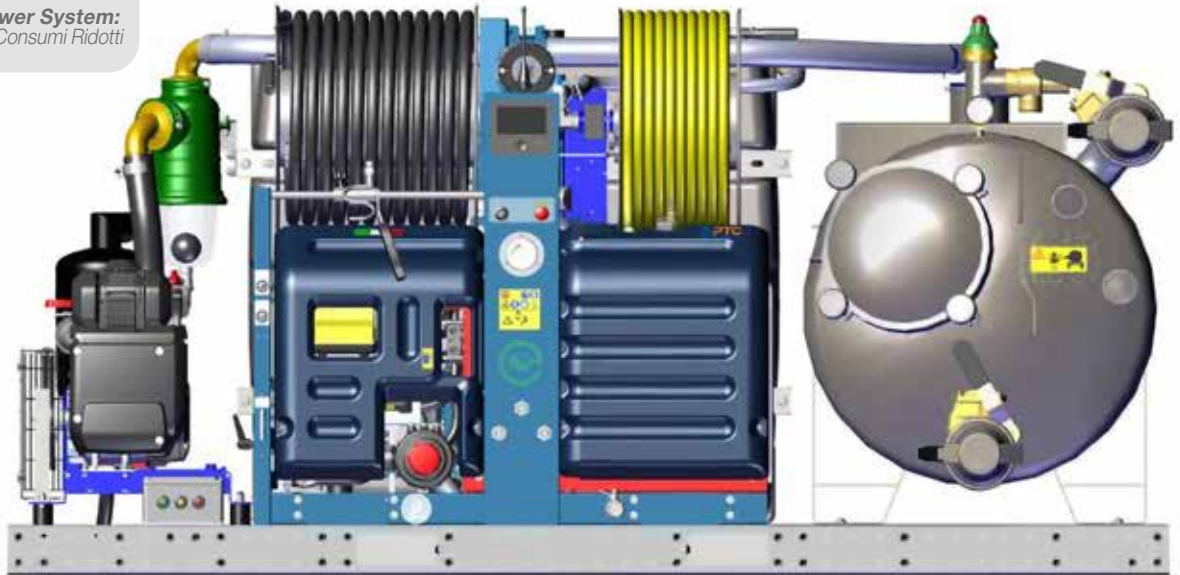

✓ Standard



Multi-function radio control for remote control (Whale complete, and ON-OFF Vortex)

*Radio comando multi-funzione per comando a distanza (Whale complete, e ON-OFF Vortex)*

✓ Standard



Easy handling thanks to the lower loading pockets

*Facilità di movimentazione grazie alle tasche di carico inferiori*

✓ Standard



PLC display for machine management.

*Schermo a colori PLC per gestire la macchina.*



Electric high pressure hose reel

*Avvolgitubo alta pressione elettrico*



**GENERAL FEATURES · CARATTERISTICHE GENERALI**

- High quality steel frame with forklift pocktes
- Vacuum resistant stainless steel tank
- Slide vanes professional vacuum pump with 4 ways-valve for change over vacuum or pressure
- New Honda 3ph brushless DC electric motor with rechargeable lithium battery
- Overflow valve, safety valve + 0,5 and double level indicator
- Manhole and manual loading/discharge gate Ø 3"
- TW Comet HP volumetric water pump
- Electric motor managed by inverter powered by a 17,6 kWh lithium battery pack
- Automatic engine speed regulation to optimize energy consumption and maximize the autonomy
- High pressure electric hose reel mx 80m of 1/2" hose and manual reel with 35m of 3/4" low pressure filling hose
- Multi-functions remote control 11 channels (on/off vacuum, on/off hp machine, on/off water, +/- pressure, wind/unwind electric reel, emergency button)
- Modular water tank capacity of 400lt
- CPS - Control Power System: Consumption management system based on the required power.

- Telaio in acciaio di alta qualità con tasche per forche
- Cisterna in acciaio inox resistente al vuoto
- Pompa per vuoto professionale a palette scorrevoli con valvola a 4 vie per commutazione vuoto/pressione
- Nuovo motore elettrico Honda trifase brushless DC con batteria al litio ricaricabile
- Valvola di troppo pieno, valvola di sicurezza + 0,5 e doppio indicatore di livello
- Boccaporto e portello di carico/scarico manuale Ø 3"
- Pompa volumetrica ad alta pressione TW Comet
- Motore elettrico gestito da inverter alimentato da un pacco batterie al litio da 17,6 kWh
- Regolazione automatica della velocità del motore per ottimizzare il consumo energetico e massimizzare l'autonomia
- Avvolgitubo elettrico alta pressione max 80 m di tubo 1/2" e avvolgitubo manuale con 35 m di tubo 3/4" per riempimento a bassa pressione
- Radiocomando multifunzione a 11 canali (on/off vuoto, on/off macchina HP, on/off acqua, +/- pressione, avvolgimento/svolgimento avvolgitubo elettrico, pulsante di emergenza)
- Serbatoio acqua modulare capacità 400 lt
- CPS - Control Power System: Sistema di gestione dei consumi in base alla potenza richiesta



Case with rechargeable lithium-ion battery  
Valigetta con batteria al litio ricaricabile



Air-cooled fast charger  
Caricabatteria rapido con raffreddamento ad aria

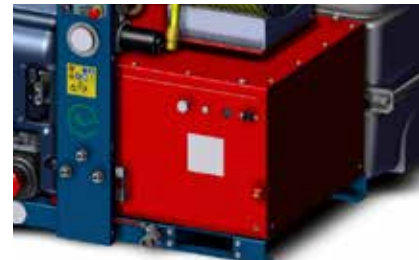

17,6 kW lithium batteries. Autonomy 3300 lt at full power. Recharge 0-100% in 3 hours (400V). Normal 220V charging available. Battery charger on request  
Batterie al litio 17,6 Kw. Autonomia massima 3300 lt a piena potenza. Ricarica 0-100% in 3.5 ore (400V). Disponibile 220V carica normale. Caricabatteria optional

**TECHNICAL FEATURES · CARATTERISTICHE TECNICHE**

MODELS MODELLI							
	l/min - bar	l/min	lt	lt	HP kW	cm (L x W x H)	kg
Vortex Combi 400 Whale E	55 - 160	1260	400	400	11,8 + 24 8,8 + 17,9	180x137x155	≥ 650



**VERSION 1 / VERSIONE 1**

Dimensions / Dimensioni cm (L x W x H): 229 x 150 x 115  
Weight / Peso Kg: 790



**VERSION 2 / VERSIONE 2**

Dimensions / Dimensioni cm (L x W x H): 185 x 150 x 157  
Weight / Peso Kg: 790

**STANDARD ACCESSORIES · ACCESSORI STANDARD**



5 m hose Ø 60 mm for suction with steel quick coupling  
5 mt tubo Ø 60 mm per l'aspirazione con innesto rapido inox



5 m hose Ø 100 mm for suction with steel quick coupling for unload tank  
5 mt tubo Ø 100 mm per l'aspirazione con innesto rapido inox per scarico cisterna



PVC suction rigid tip Ø 80 mm with valve  
Pescante a puntale rigido in PVC Ø 80 mm per aspirazione con valvola



UNI 45 / STORZ kit for water hydrant connection  
Kit UNI 45 / STORZ per connessione idrante acqua

**ACCESSORIES ON REQUEST · ACCESSORI A RICHIESTA**

# VORTEX COMBI CLEANING

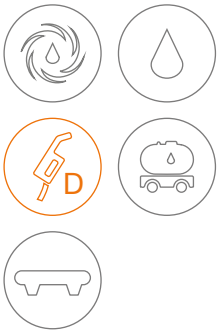

Double level indicator  
*Doppio indicatore di livello*

Manual loading and discharge brass valve

*Valvola di carico e scarico manuale in ottone*



Manual hose reel for 15 m of washing hose

*Naspo manuale per 15 m di tubo da lavaggio*

Stainless steel tank and frame with forklift support for easy handling

*Serbatoio e telaio in acciaio inossidabile con supporto per carrello elevatore per una facile movimentazione e collettore troppo pieno*



**GENERAL FEATURES · CARATTERISTICHE GENERALI**

- High quality steel frame with forklift pockets
- N. 2 Yanmar diesel engines
- Sliding vanes professional vacuum pumps
- Comet HP pumps
- 800 l Stainless Steel sewage tank, overflow valve, +0,5 bar safety valve, double sight level indicator, manual loading/ discharge valve
- 200 l plastic water tank
- HP manual hose reel with 15 mt hose
- 5 m hose Ø 80 mm, for suction with quick coupling
- Telaio di alta qualità in acciaio con predisposizione per sollevamento tramite forche muletto
- N. 2 motori diesel Yanmar
- Pompe da vuoto professionali a palette
- Pompe HP Comet
- Cisterna in acciaio inox 800 l, valvola di troppo pieno, valvola sicurezza +0,5 bar, doppio indicatore di livello, valvola di carico/scarico manuale
- Cisterna acqua in plastica 200 l
- Naspo HP manuale con 15 metri di tubo
- 5 m tubo Ø 80 mm, per l'aspirazione con innesto rapido



**TECHNICAL FEATURES · CARATTERISTICHE TECNICHE**

MODELS MODELLI	l/min - bar	l/min	lt	lt	HP	kW	cm (L x W x H)	kg
Vortex Combi Cleaning D Cold water	15 - 150	2750	200	800	10,8	8	105x234x140	≥ 520

Data refers to standard configurations. Available on request with diesel/hydraulic/electric motor and with different volumes tanks · Dati riferiti alle unità con dotazione standard. Disponibile su richiesta con motore diesel/idraulico/elettrico e con cisterne di volumi differenti

**ACCESSORIES ON REQUEST · ACCESSORI A RICHIESTA**



Gun kit with different type of cleaning lances  
Kit pistola con varie tipologie di lance da lavaggio



5 m hose Ø 80 mm for suction with steel quick coupling  
5 mt tubo Ø 80 mm per l'aspirazione con innesto rapido inox



PVC suction rigid tip Ø 80 mm with valve  
Pescante a puntale rigido in PVC Ø 80 mm per aspirazione con valvola



# High Pressure Cleaning

- Surface preparation
  - Facade cleaning
  - sandblasting
  - Cleaning of floors, street furniture, tram lines, industrial equipment, tanks, plants
  - descaling
  - Stripping
  - Removal: glues, paints, chewingum, writings, graffiti, organic residues, incrustations and polluting deposits on any surface.
  - Steam weeding without the addition of chemicals
  - Cleaning, degreasing and sanitizing
- *Preparazione superfici*
  - *Pulizia facciate*
  - *Idrosabbatura*
  - *Pulizia di pavimentazioni, arredi urbani, linee tramviarie, attrezzature industriali, cisterne, impianti*
  - *Disincrostazione*
  - *Sverniciatura*
  - *Rimozione: colle, vernici, chewingum, scritte, graffiti, residui organici, incrostazioni e depositi inquinanti su qualsiasi superficie.*
  - *Diserbo a vapore senza l'aggiunta di agenti chimici*
  - *Pulizia, sgrassatura e igienizzazione*





## High Pressure Cold and Hot Water Hydrodynamic Units

### Unità Idrodinamiche alta pressione ad acqua fredda e calda



High Pressure Cleaning units, professional washing machines that combine the power of pressurized water with the sanitizing action of hot water and steam, allowing cleaning operations without the use of detergents and chemical additives. A solution that improves the quality and working conditions of operators, respecting the environment and reducing intervention costs.



Unità High Pressure Cleaning, macchine da lavaggio professionale che combinano la forza dell'acqua in pressione all'azione igienizzante dell'acqua calda e vapore, permettendo interventi di pulizia senza l'impiego di detersivi e additivi chimici. Una soluzione che migliora la qualità e le condizioni di lavoro degli operatori, rispettando l'ambiente e riducendo i costi di intervento.

## CONFIGURATIONS · CONFIGURAZIONI

## UNITS · UNITÀ



### PORTABLE

Portable units with electric motor for rapid professional cleaning. Simplicity of use and easy handling characterize this type of product.

Unità portatili con motorizzazione elettrica per rapidi interventi di pulizia professionale. Semplicità di utilizzo e facile movimentazione caratterizzano questa tipologia di prodotto.

TORPEDO MINI-E



### SKID

The Skid configuration permits use on platforms and roll-offs without any changes having to be made to the vehicle. These units are easy to transport and fully independent.

La configurazione Skid permette l'installazione dell'unità su pianali e scarrabili senza richiedere alcuna modifica all'automezzo. Queste unità sono facilmente trasportabili e completamente autonome.

TORNADO SKID

TORPEDO COMPACT

TORPEDO SKID

TORPEDO ELECTRIC



### TRAILER

Trailer units, professional trailers approved for road use with petrol or diesel engines and versions up to 750kg or up to 1500Kg at full load. While maintaining the characteristics of the range, these units make it possible not to constrain the load compartment of a vehicle and avoid the traffic restrictions imposed on large vehicles.

Unità Trailer, rimorchi professionali omologati per la circolazione stradale con motorizzazioni benzina o diesel e versioni fino a 750kg o fino a 1500Kg a pieno carico. Pur mantenendo le caratteristiche di gamma, queste unità consentono di non vincolare il vano di carico di un automezzo ed evitano le limitazioni di traffico imposte ai veicoli di grandi dimensioni.

CTR-H

JTR-H



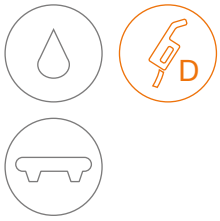

# TORNADO SKID



Version  
with PE  
tank 500 l

Versione  
con tanica  
in PE 500 l



Recoil HP hose reel (30 m 3/8" hose)

Naspo alta pressione automatico (30 m tubo 3/8")



Tornado. Suitable for vehicle like Piaggio Porter/Maxi

Tornado. Adatto per veicoli come Piaggio Porter/Maxi



UNI 45 water hydrant connection

Attacco UNI 45 kit riempimento cisterna



**RW**

Pump with gearbox

Pompa con riduttore di giri



**GENERAL FEATURES · CARATTERISTICHE GENERALI**

- High quality painted steel frame with provision for lifting by forklift forks
- Honda / Vanguard petrol Engine, Yanmar Diesel engine
- Comet pump mod. RW with gearbox
- High pressure hose reel with automatic winding complete with 20 m of 3/8" hose
- 500 l PE tank with level indicator and water shortage alarm.
- UNI-45 kit for tank filling
- Soundproof cabin
- Telaio in acciaio verniciato di alta qualità con predisposizione per sollevamento tramite forche muletto
- Motore a benzina Honda / Vanguard, motore diesel Yanmar
- Pompa Comet mod. RW con riduttore
- Naspo alta pressione ad avvolgimento automatico completo di 20 m di tubo da 3/8"
- Serbatoio in PE da 500 l con indicatore di livello e allarme mancanza acqua.
- Kit UNI-45 per riempimento cisterna
- Cabina insonorizzata

**CUSTOMIZED VERSIONS · VERSIONI PERSONALIZZATE**



Version with silent cab · Versione con cabina silenziosa

**TECHNICAL FEATURES · CARATTERISTICHE TECNICHE**

MODELS MODELLI	I/min	bar	type	HP	kW	500 lt cm (L x W x H)	kg
Tornado 18/250	18	250	Vanguard	14	10,5	130x170x112	≥ 500
Tornado 23/200	23	200					
Tornado 28/250	28	250	Honda	24	17,7	130x170x112	≥ 500
Tornado 36/200	36	200					
Tornado 15/200	15	200	DIESEL Yanmar	9,3	7	130x170x112	≥ 500
Tornado 18/160	18	160					

Data refers to standard configurations · Dati riferiti alle unità con dotazione standard

**ACCESSORIES ON REQUEST · ACCESSORI A RICHIESTA**



Gun kit with different type of cleaning lances  
Kit pistola con varie tipologie di lance da lavaggio



100 kW-12 VDC auxiliary hot water mobile generator  
Generatore mobile di acqua calda 100 kW-12 VCC ausiliario



M24x1,5 floorwash kit  
Kit lavapavimenti M24x1,5



Hydro-sandblasting kit  
Kit per idrosabbatura

## VERSIONS · VERSIONI



# POWERSTEAM VERSION

Developed for professional washing of surfaces that require special attention, taking advantage of the combination of high pressure and high temperature without the use of chemical additives, to avoid damage to the surfaces. This high pressure steam cleaning technique at around 150° C with an adjustable pressure up to 220 bar, brings excellent cleaning results with minimum water and fuel consumption.

*Sviluppata per il lavaggio professionale di superfici che richiedono una attenzione particolare, sfruttando il connubio tra l'alta pressione e l'alta temperatura senza l'utilizzo di additivi chimici, per evitare il danneggiamento delle superfici. Questa tecnica di lavaggio a vapore ad alta pressione a 150° C circa con una pressione regolabile fino a 220 bar, porta risultati di pulizia eccellenti con consumi minimi di acqua e carburante.*

**An ideal application for cleaning:**

- Monuments, squares and floors
- Fragile facades
- Removing chewingum and graffiti
- Bridges and scaffolding
- Oil, fats and resins
- Algae and mosses
- Air pollution
- Vertical and horizontal signs

**Un applicazione ideale per la pulizia di:**

- Monumenti, piazze e pavimentazioni
- Facciate fragili
- Rimozione chewingum e graffiti
- Ponti e ponteggi
- Olio, grassi e resine
- Alghe e muschi
- Inquinamento atmosferico
- Segnaletica verticale e orizzontale

**TORPEDO MINI-E**

**TORPEDO COMPACT**

**CTR-H PS**

**JTR-H PS**



## WEED CONTROL VERSION

The New WEED CONTROL system GUARANTEES COMPLETE REMOVAL of weeds, without any injury from chemical agents to people or damage to the surrounding environment, respecting the current European regulations. The effectiveness of ecological weeding is given by the intensity of the water steam emitted by the unit. The localized jet creates a thermal rise localized on the weed by eliminating it in a few steps.

*Il nuovo sistema WEED CONTROL, GARANTISCE la RIMOZIONE COMPLETA di erbe infestanti, senza nessun danno da agenti chimici alle persone e all'ambiente circostante rispettando le vigenti normative europee. L'efficacia del diserbo ecologico è data dall'intensità del vapore acqueo sprigionato dall'unità. Il getto localizzato crea un innalzamento termico localizzato sulla pianta infestante eliminandola in pochi passaggi.*



**TORPEDO COMPACT**



**TORPEDO SKID**



**CTR-H**



**JTR-H**

# TORPEDO MINI-E



**NEW**  
POWERSTEAM  
system



Handle for practical use  
*Maniglia per un uso pratico*



Single central bar for vertical lifting with crane or winches  
*Barra centrale per sollevamento verticale con gru o argani*



Professional control panel  
*Pannello di controllo professionale*



High efficiency stainless steel boiler. Anti-scale device with pump and tank  
*Caldia in acciaio inox ad alta efficienza. Dispositivo anticalcare con pompa e serbatoio*



## GENERAL FEATURES · CARATTERISTICHE GENERALI

- 25-litre capacity fuel tank with level float and fill up filter
- Water suction from a tank with an integrated and readily serviceable suction cartridge filter
- Anti-scale device with pump and tank (2,5 l)
- Professional 4-pole motor (1400 rpm) with Comet ZW pump and professional unloader bolt-on valve
- Delayed TotalStop
- General stop (when the machine is not used for a long time)
- EASY-START
- PowerSteam
- Flow-switch controlled burner
- Professional safety valve
- Boiler thermal protection
- Electronic temperature setting system with constant water temperature
- Delayed burner start
- Separate boiler fan unit
- Professional use
- Serbatoio carburante da 25 litri con galleggiante di livello e filtro di riempimento
- Aspirazione acqua da serbatoio con un filtro a cartuccia di aspirazione integrato e facilmente riparabile
- Dispositivo anticalcare con pompa e serbatoio (2,5 l)
- Motore professionale a 4 poli (1400 giri/min) con pompa Comet ZW e valvola di avvitalamento professionale scaricatore
- TotalStop ritardato
- Arresto generale (quando la macchina non viene utilizzata per molto tempo)
- Easy-start
- PowerSteam
- Bruciatore controllato da flussostato
- Valvola di sicurezza professionale
- Protezione termica della caldaia
- Sistema elettronico di regolazione della temperatura con temperatura dell'acqua costante
- Avvio ritardato del bruciatore
- Ventilatore caldaia separato
- Uso professionale

## TECHNICAL FEATURES · CARATTERISTICHE TECNICHE

MODELS MODELLI	PUMP	Ph		V		Hz		bar		MPa		l/min		HP		kW		kW		°C		lit		kg/h		kg		(L x W x H) cm	
		Ph	V	Hz	bar	MPa	l/min	HP	kW	kW	°C	lit	kg/h	kg	(L x W x H) cm														
 Torpedo Mini-E 3.8 M 230/50 Powersteam	ZW	1	230	50	160	16	8	3	2,2	2,9	150	25	3,5	120	110 x 64 x 98														
 Torpedo Mini-E 5.8 T 400/50 Powersteam	ZW	3	400	50	200	20	8	5	4,0	4,0	150	25	3,5	120	110 x 64 x 98														

## STANDARD EQUIPMENT · DOTAZIONE STANDARD



Gun with lance kit



Fan shape nozzle 25°, 1/4" MEG connection



10 m rubber delivery hose kit

# TORPEDO COMPACT



**Green Power**  
**WEED CONTROL**  
system

**NEW**  
**POWERSTEAM**  
system



New design, light and compact, with integrated boiler

*Nuovo design, leggero e compatto, con caldaia integrata*



Complete and intuitive control panel for equipment and boiler management

*Quadro comandi completo ed intuitivo per la gestione dell'attrezzatura e della caldaia*

Automatic HP hose reel (max 20 m 3/8" - standard)

*Naspo HP automatico (max 20 m 3/8" in dotazione)*



Compact dimensions  
Suitable for small van or vehicles like Porter Maxi

*Dimensioni compatte che lo rendono adatto a piccoli furgoni o veicoli come Porter Maxi*

Easy movements thanks to the lower loading pockets

*Facile movimentazione grazie alle tasche di carico inferiori*



**GENERAL FEATURES · CARATTERISTICHE GENERALI**

- High quality painted steel frame with forklift pockets
  - Stainless steel covers
  - Kohler diesel engines liquid cooling with electric starter
  - RW/TW Premium Comet pumps with gearbox
  - Pressure gauge, manual pressure regulator, safety valve
  - Automatic/manual high pressure hose reel with max 20 m 3/8"
  - Diesel boiler with electronic temperature control system
  - Anti-scale pump device
  - 300/400/500 l tank kit (on request)
- Telaio di alta qualità in acciaio verniciato con predisposizione per sollevamento tramite forche muletto
  - Cofanature in acciaio inox
  - Motori diesel Kohler raffreddamento a liquido con avviamento elettrico
  - Pompe RW/TW Premium Comet con riduttore di giri
  - Manometro, regolatore di pressione manuale, valvola di sicurezza
  - Naspo alta pressione automatico/manuale con max 20 m 3/8"
  - Caldaia diesel con regolazione elettronica della temperatura
  - Dispositivo anticalcare
  - Kit serbatoio da 300/400/500 l (su richiesta)

**CUSTOMIZED VERSIONS · VERSIONI PERSONALIZZATE**

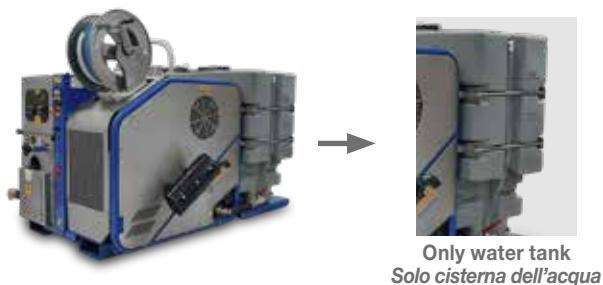

Complete version with 300/400/500 l tank kit and UNI-45 filling kit  
Versione completa con kit serbatoio da 300/400/500 l e kit UNI-45 per riempimento



**POWERSTEAM VERSION / VERSIONE**  
with manual hose reel (on 16/250 ps - 16/350 ps models)  
con naspo manuale (su modelli 16/250 ps - 16/350 ps)

**TECHNICAL FEATURES · CARATTERISTICHE TECNICHE**

MODELS MODELLI														
	l/min	bar	type	HP	kW	cm (L x W x H)	kg	cm (L x W x H)	kg	cm (L x W x H)	kg			
Torpedo Compact 23/250	23	250	Kohler	26	18,9	120,5x125x133	≥ 480	190x125x133	≥ 550	190x125x133	≥ 550			
Torpedo Compact 23/350	23	350	Kohler	26	18,9	120,5x125x133	≥ 480	190x125x133	≥ 550	190x125x133	≥ 550			
Torpedo Compact 16/350 PS	16	350	Kohler	26	18,9	120,5x125x133	≥ 480	190x125x133	≥ 550	190x125x133	≥ 550			

Data refers to standard configurations · Dati riferiti alle unità con dotazione standard

**ACCESSORIES ON REQUEST · ACCESSORI A RICHIESTA**



Gun kit with different type of cleaning lances  
Kit pistola con varie tipologie di lance da lavaggio



M24x1,5 floorwash kit  
Kit lavapavimenti M24x1,5



Hydrosandblasting kit  
Kit per idrosabbatura



Lancia a vapore per diserbo angolata e carrellata  
Bent and wheeled weed killer steam lance

# TORPEDO SKID



Dimensions suitable for flatbed vehicles like Porter Maxi/Ducato

*Dimensioni adatte per veicoli a pianale come Porter Maxi / Ducato*

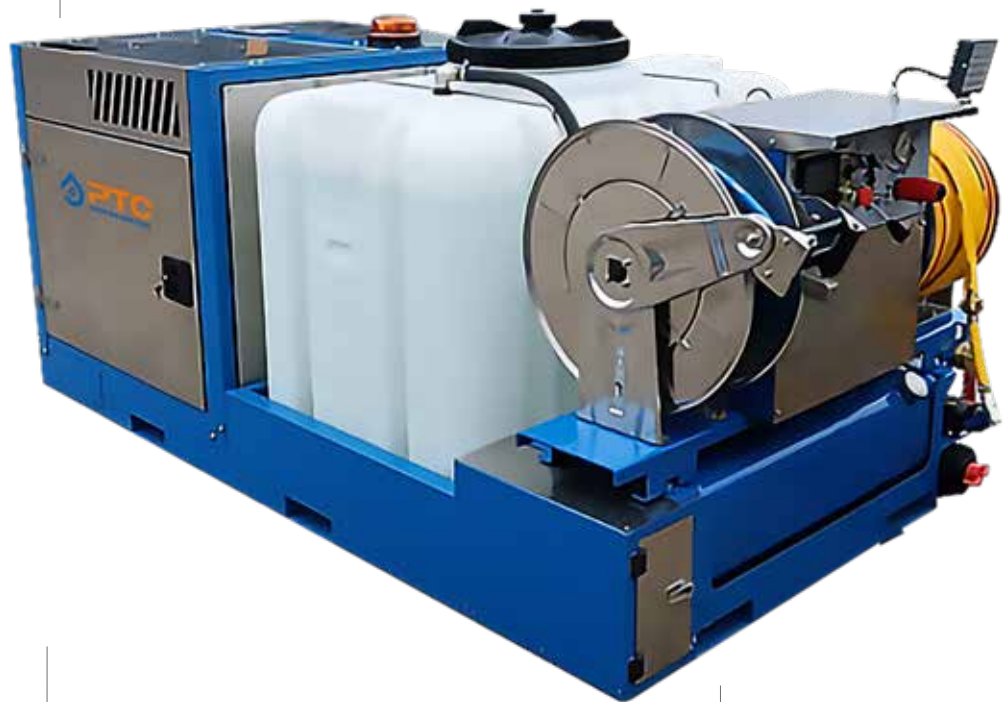

Large integrated lance holder

*Ampia cassetta portalance integrata*



Frame with forklift pockets

*Telaio con inserti per sollevamento tramite muletto*



Version with soundproofed cab

*Versione con cabina insonorizzata*



**GENERAL FEATURES · CARATTERISTICHE GENERALI**

- High quality painted steel frame with forklift pockets
  - Water cooled Kohler diesel engines with electric starter
  - Manual throttle control
  - TW Premium Comet pumps with gear box
  - Pressure gauge, pressure regulator, safety valve and manual throttle control
  - Automatic high pressure reel max 30 m of 3/8" hose
  - Manual hose reel with 35m of 3/4" hose for refill or second HP reel
  - 80/100 kw diesel heater with electronic temperature control system and anti-scale device
  - 20/50 m of high pressure hose 3/8" (not included)
  - PE water tank of 680 or 1000 l (at choice)
  - Soundproof cabin
  - Upper pivoting jib (not included)
  - Line pre-heating and cooling without wasting water
  - TOTAL STOP
- Telaio di alta qualità in acciaio verniciato con predisposizione per sollevamento tramite forche muletto
  - Motori diesel Kohler raffreddati ad acqua con avviamento elettrico
  - Acceleratore di giri manuale
  - Pompe TW Premium Comet con riduttore
  - Manometro, regolatore di pressione, valvola di sicurezza e controllo manuale dell'acceleratore
  - Naspo alta pressione max 30m di tubo da 3/8"
  - Avvolgitubo manuale con tubo da 35 m da 3/4" per ricarica o secondo naspo HP
  - Caldaia diesel 80/100 kw con sistema elettronico di controllo della temperatura e dispositivo anticalcare
  - 20/50 m di tubo ad alta pressione da 3/8" (non incluso)
  - Serbatoio acqua PE da 680 o 1000 l (a scelta)
  - Cabina insonorizzata
  - Braccio a bandiera superiore (non incluso)
  - Pre riscaldamento linea e raffreddamento senza sprechi d'acqua
  - TOTAL STOP

**CUSTOMIZED VERSIONS · VERSIONI PERSONALIZZATE**

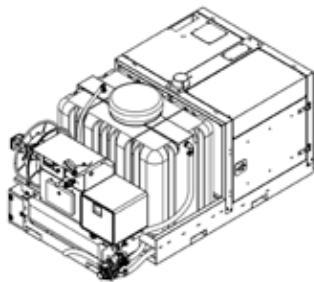

Equipped with a tool box instead of the second hose reel, it can be used as a UNI 45 hose holder  
 Corredato con cassetta portattrezzi al posto del secondo avvolgitubo, può essere utilizzata come porta manichetta UNI 45

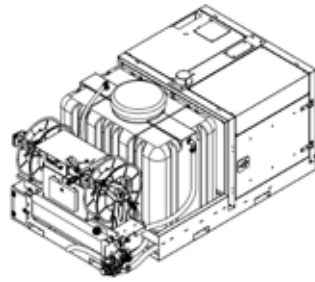

Can be used as a double operator or as a single operator with 2 different hose lengths  
 Utilizzabile come doppio operatore o come singolo con 2 lunghezze tubo differenti

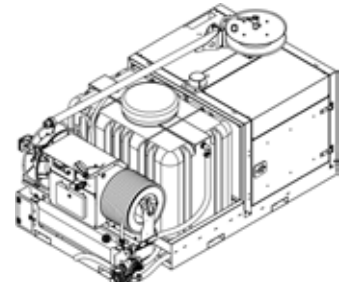

With upper swing arm  
 Con braccio a bandiera superiore

**TECHNICAL FEATURES · CARATTERISTICHE TECNICHE**

MODELS MODELLI	l/min	MAX bar	type HP kW	680 lt cm (L x W x H)	kg	1x 1000 lt cm (L x W x H)	kg
Torpedo 23/250	23	250	Kohler 26 19	With soundproof cabin: / Con cabina insonorizzata: 243 x 134 x 116	≥ 600	With soundproof cabin: / Con cabina insonorizzata: 243 x 134 x 158	≥ 600
Torpedo 23/350	23	350	Kohler 26 19				

**ACCESSORIES ON REQUEST · ACCESSORI A RICHIESTA**



Gun kit with different type of cleaning lances  
 Kit pistola con varie tipologie di lance da lavaggio



M24x1,5 floorwash kit  
 Kit lavapavimenti M24x1,5



Hydrosandblasting kit  
 Kit per idrosabbatura



Lancia a vapore per diserbo angolata e carrellata  
 Bent and Wheeled weed killer steam lance



# CTR-H

**European homologation - Approved for road transport, category O2, max 750 kg. Only driving licence B required (750 kg)**  
*Omologazione Europea - Omologato per il trasporto stradale, categoria O2, max 750 kg. Utilizzabile con patente B (≤ 750 kg)*

**Green Power**

**WEED CONTROL**  
system



**NEW POWERSTEAM**  
system

Manual low-pressure hose reel, Max 35 m 3/4"

*Naspo bassa pressione manuale, Max 35 mt 3/4"*



Manual HP hose reel, Max 60 m 1/2" - 80 m 3/8"

*Naspo HP manuale, Max 60 mt 1/2" - 80 mt 3/8"*

New design with ABS cover and key-lock system

*Nuovo design con cover in ABS e sistema di chiusura a chiave*



Complete and intuitive control panel for equipment and boiler management

*Quadro comandi completo ed intuitivo per la gestione dell'attrezzatura e della caldaia*



75 kW high-efficiency boiler

*Caldaia 75 kW ad elevata efficienza*



Housing lance

*Porta-lancia*

**Approved for road transport, category O2, max 750 kg. Only driving licence B required (750 kg)**  
*Omologato per il trasporto stradale, categoria O2, max 750 kg. Utilizzabile con patente B (≤ 750 kg)*



**GENERAL FEATURES · CARATTERISTICHE GENERALI**

- Single axle trailer with rear lights and reflectors, automatic reverse gear, parking brakes, ABS and Mudguards
- Towing eye for a 50 mm diam. sphere type
- Kohler liquid cooled diesel engines with electric start
- Comet RW and TW Premium pumps with gearbox
- 200 litre polyethylene water tank, fuel tank 43 lt
- Diesel heater with anti-scale device and temperature regulation
- Pressure gauge, pressure regulator, safety valve and manual throttle control
- Manual high pressure hose reel max 50mt of hose
- Low pressure hose reel with 35m hose for filling
- Housing for gun and lance
- Beacon light
- 20 / 50m of 3/8 "high pressure hose (not included)
- Working light (not included)
- Carrello monoasse con luci posteriori e riflettori, retromarcia automatica, freno di stazionamento, ABS e parafanghi
- Occhiello sferico di traino diametro 50 mm
- Motori diesel raffreddati a liquido Kohler con avviamento elettrico
- Pompe RW e TW Premium Comet con riduttore di giri
- Serbatoio acqua in polietilene da 200 l, serbatoio carburante 43 lt
- Caldaia diesel con dispositivo anticalcare e regolazione della temperatura
- Manometro, regolatore di pressione, valvola di sicurezza e acceleratore manuale
- Naspo alta pressione manuale max 50mt di tubo
- Naspo bassa pressione con 35m di tubo per riempimento
- Alloggiamento porta pistola e lance
- Girofaro lampeggiante
- 20/50m di tubo alta pressione da 3/8" (non incluso)
- Faro da lavoro (non incluso)



A



B

**TECHNICAL FEATURES · CARATTERISTICHE TECNICHE**

MODELS MODELLI	l/min	bar	type	HP	kW	200 lt cm (L x W x H)	kg
CTR-H 21/200	21	200	Kohler	17	12,6	304,5x139x119	≥ 400
CTR-H 20/350	20	350	Kohler	26	19	304,5x139x119	≥ 400
CTR-H 16/350	16	350	Kohler	26	19	304,5x139x119	≥ 400

Data refers to standard configurations / Dati riferiti alle unità con dotazione standard.

**ACCESSORIES ON REQUEST · ACCESSORI A RICHIESTA**



Gun kit with different type of cleaning lances  
Kit pistola con varie tipologie di lance da lavaggio



M24x1,5 floorwash kit  
Kit lavapavimenti  
M24x1,5



Hydrosandblasting kit  
Kit per idrosabbatura



Lancia a vapore per diserbo angolata e carrellata  
Bent and Wheeled weed killer steam lance

# JTR-H



**Green Power**

**WEED CONTROL**  
system



**NEW**  
**POWERSTEAM**  
system



**European homologation - Approved for road transport, 1050 kg or 1500 kg GVW.**  
*Omologazione Europea - Omologato per il trasporto stradale, 1050 kg o 1500 kg di GVW massimo.*



Automatic-winding HP hose reel (versions up to 350 bar) or manual (500 bar versions)

*Naspo HP ad avvolgimento automatico (versioni fino a 350 bar) o manuale (versioni 500 bar)*



Heavy duty single axle trailer complete with high load capacity tires

*Rimorchio monoasse per utilizzi gravosi completo di pneumatici ad elevata capacità di carico*



JTR-H 23/350

JTR-H 30/500



Single boiler with anti-scale device and tank

*Singola caldaia con dispositivo anticalcare e serbatoio*



Front and rear cover and watertank in Fiberglass

*Copertura anteriore e posteriore e serbatoio dell'acqua in vetroresina*



PLC control panel

*Pannello di controllo PLC*



**GENERAL FEATURES · CARATTERISTICHE GENERALI**

- Single axle trailer with rear lights and reflectors, automatic reverse gear, parking brakes, high load tyres, ABS and Mudguards
- Towing eye for a 50 mm diam. Sphere type
- 600 l water tank with low level alarm
- Water cooled Yanmar or Kohler diesel engine with electric starter
- Manual throttle control (Automatic on 30/500)
- RW/TW Comet pump with pulley and belt transmission or reducer
- Pressure gauge, pressure regulator, safety valve and manual throttle (automatic on 30/500 model)
- Manual hose reel 500 bar high pressure version: 50m-1/2" or 3/8"; 350 bar automatic version: 30m-3/8" or 1/2"
- Manual hose reel with 35m hose for refill
- Front/Rear hoods and watertank of 600l capacity in Fiberglass
- Diesel (single or twin) heater with electronic temperature control system and anti-scale device
- High pressure hose max 20m or 50m 3/8 "(optional)
- Working light (optional)
- Carrello monoasse con luci posteriori e riflettori, retromarcia automatica, freno di stazionamento, pneumatici per carichi elevati, ABS e parafanghi
- Occhiello sferico di traino diametro 50 mm
- Serbatoio acqua 600 litri con allarme livello minimo
- Motore diesel Kohler o Yanmar raffreddato ad acqua, con avviamento elettrico
- Acceleratore di giri manuale (Automatico su 30/500)
- Pompa Comet RW/TW trasmissione a cinghia e puleggia o riduttore
- Manometro, regolatore di pressione, valvola di sicurezza e acceleratore manuale (automatico sul modello 30/500)
- Avvolgitubo alta pressione versione 500 bar manuale: 50m-1/2" or 3/8"; 350 bar versione automatico: 30m-3/8" o 1/2"
- Avvolgitubo manuale con tubo da 35 m per ricarica
- Cofanature anteriori / posteriori e serbatoio d'acqua di capacità 600l in vetroresina
- Caldaia diesel (singola o doppia) con sistema elettronico di controllo della temperatura e dispositivo anticalcare
- Tubo alta pressione max 20m o 50m 3/8 "(optional)
- Faro di lavoro (optional)



**TECHNICAL FEATURES · CARATTERISTICHE TECNICHE**

MODELS MODELLI	l/min	bar	type	HP	kW	600 lt	cm (L x W x H)	kg
JTR-H 21/200	21	200	Kohler	17	12,6	337x164x154	≥ 900	
JTR-H 23/350 T	23	350	Kohler	26	19	337x164x154	≥ 900	
JTR-H 23/350	23	350	Kohler	26	19	337x164x154	≥ 900	
JTR-H 30/500	30	500	Yanmar	48	35,5	337x164x154	≥ 900	

**ACCESSORIES ON REQUEST · ACCESSORI A RICHIESTA**

<p>Gun kit with different type of cleaning lances Kit pistola con varie tipologie di lance da lavaggio</p>	<p>M24x1,5 floorwash kit Kit lavapavimenti M24x1,5</p>	<p>Hydrosandblasting kit Kit per idrosabbatura</p>	<p>Lancia a vapore per diserbo angolata e carrellata Bent and Wheeled weed killer steam lance</p>
--	--	--	---



# TORPEDO ELECTRIC

72 Volt

600l capacity with modular tanks

*600l di capacità con serbatoi modulari*

N. 2 high pressure automatic hose reels

*N. 2 naspi alta pressione a bandiera ad avvolgimento automatico*

Green Power

**WEED CONTROL**  
system



Torpedo Electric on vehicle

*Torpedo Electric su veicolo*

Diesel heater with electronic temperature control and anti-scale device

*Caldaia diesel integrata con controllo della temperatura elettronico e dispositivo anticalcare*





## COLD AND HOT WATER ELECTRIC CLEANING UNIT

Cold and hot water cleaning unit designed for use on electric vehicles, for professional cleaning and maintenance of urban areas, as well as for the ecological weeding of public green areas, without the use of chemical additives.

## UNITÀ DA LAVAGGIO ELETTRICA AD ACQUA FREDDA E CALDA

Unità da lavaggio ad acqua fredda e calda concepita per l'utilizzo su veicoli elettrici, per la pulizia professionale e manutenzione delle aree urbane, nonché per il diserbo ecologico del verde pubblico, senza l'utilizzo di additivi chimici.

### TECHNICAL FEATURES · CARATTERISTICHE TECNICHE

MODELS MODELLI	WASHING PROGRAM PROGRAMMA DI LAVAGGIO	 l/min	 bar	 600 lt cm (L x W x H)
Torpedo Electric 14/220	POWER 	14	220	141x127x135 Arm-Braccio: 213
	NORMAL 	13	190	
	ECO 	11	160	

### ACCESSORIES ON REQUEST · ACCESSORI A RICHIESTA



Gun kit with different type of cleaning lances  
Kit pistola con varie tipologie di lance da lavaggio



M24x1,5 floorwash kit  
Kit lavapavimenti  
M24x1,5



Hydrosandblasting kit  
Kit per idrosabbatura



Lancia a vapore per diserbo angolata e carrellata  
Bent and Wheeled weed killer steam lance







[www.ptcitaliana.com](http://www.ptcitaliana.com)



PTC Srl · Via Mantegna n. 4 · 42048 Rubiera (RE) ITALY  
Phone +39 0522 626477 · Email [sales@ptcitaliana.com](mailto:sales@ptcitaliana.com)  
Website [www.ptcitaliana.com](http://www.ptcitaliana.com)

